

ANT BMS 16S wiring diagram

ANT BMS 16S	work current	peak current
Li-ion(3.7V) : 7S to 16S	50A	100A
LiFePo4(3.2V) : 8S to 16S	100A	320A
LTO(2.4V) : 10S to 16S		

Peak current mean can support 30 seconds. Eg: 16S 100A version, current 320A can support 30 seconds





lgx.com.ua



lgx.com.ua

Active the BMS

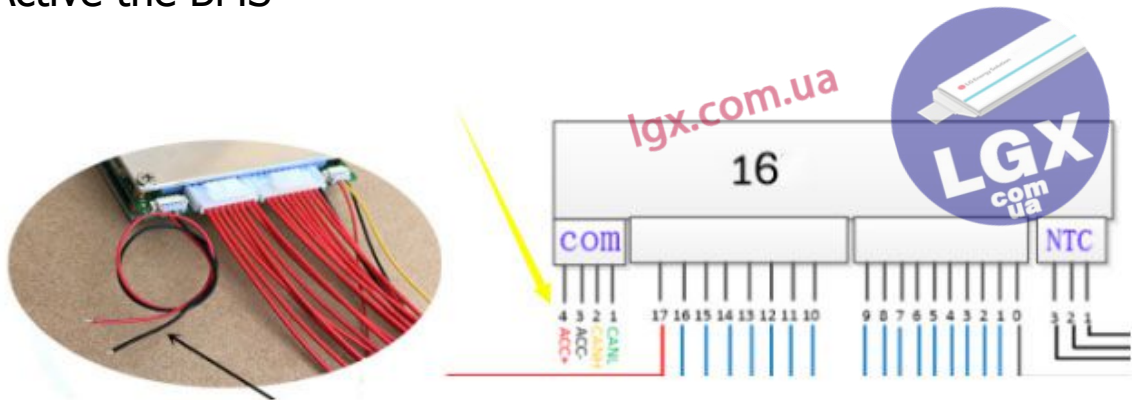

CAN	name	description
1	CAN_L	CAN bus low signal
2	CAN_H	CAN bus high signal
3	ACC-	Active signal negative
4	ACC+	Active signal positive

RS485	name	description
1	485B	RS485_B signal
2	485A	RS485_A signal
3	ACC-	Active signal negative
4	ACC+	Active signal positive

UART	name	description
1	RXD	RXD signal for UART
2	TXD	TXD signal for UART
3	GND	GND signal for UART
4	VCC	VCC signal for UART

Note: LCD(UART) and CAN and RS485 share the same port, it's decide by the software and hardware.

CAN or RS485 or UART share the same port. We send the correct version base your order.

Eg: if you order LCD version. Then the communication port configure to UART port. LCD use UART port to communication.

eg: if configure to CAN, the signal is CAN_L and CAN_H.

eg: If configure to RS485, the signal is 485B(CAN_L) and 485A(CAN_H)

This BMS have three method to active(power on)

1. Use charger to charge the BMS, can active the BMS.

2. Use the LCD to activate the BMS.
3. Use the active signal. Add 3V to 5V voltage in ACC signal. Then can power on the BMS. Suggestion use the voltage of one cell. add voltage, just 2 seconds then can active, then can disconnect the active voltage. After the BMS active, you will hear the "beep", also find the red led is turn on.

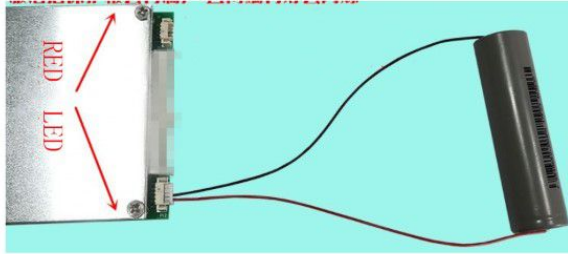

use 3V to 5V, just 2 seconds, then can active BMS, then can disconnect the active voltage

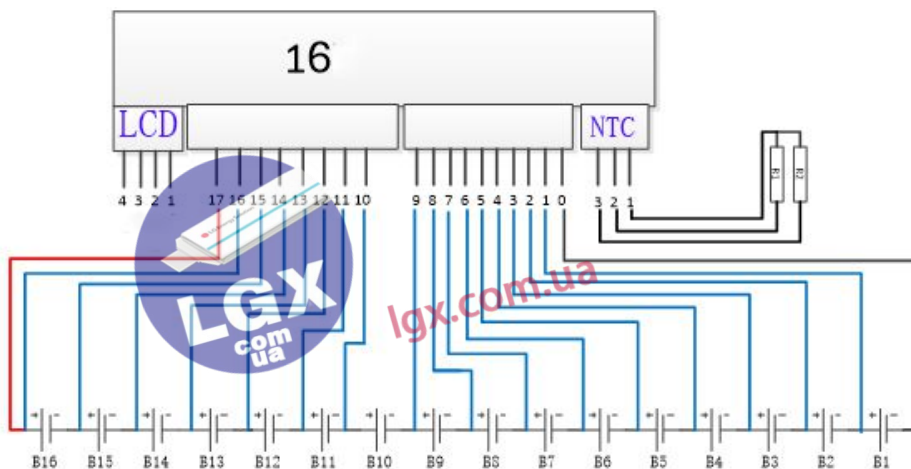
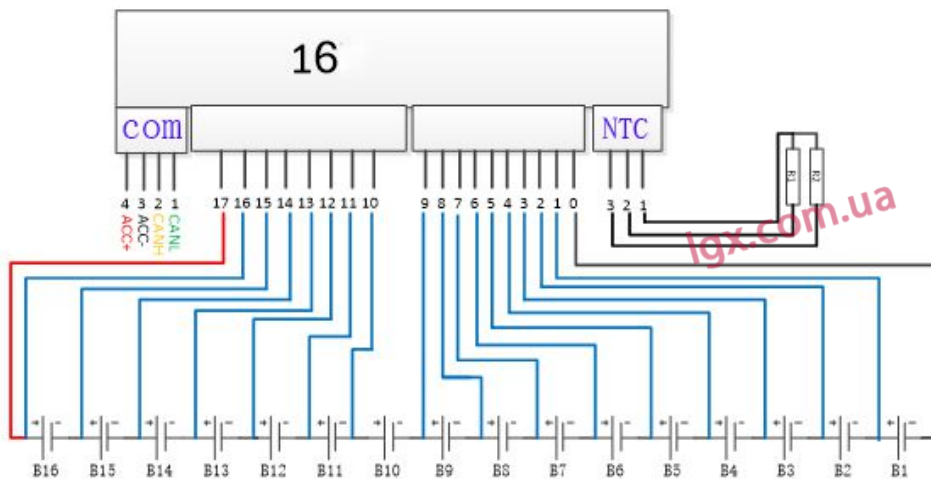

NTC

	name	description
1	GND	The GND of NTC
2	T1	NTC1 positive
3	T2	NTC2 positive

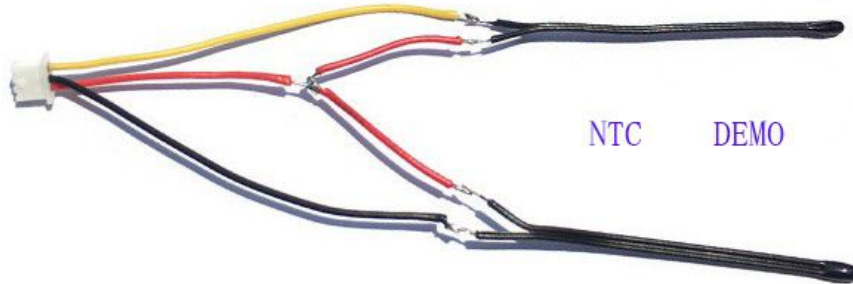

note: this photo is not a good DEMO.
suggestion GND use black wire.

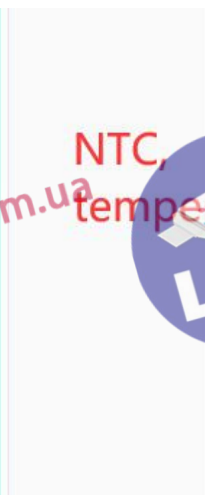
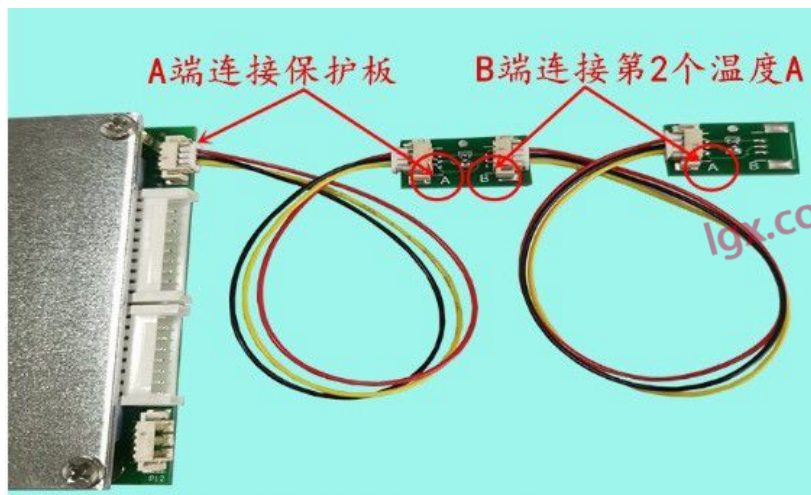

LCD communication wiring

BMS side: red, black, yellow, green.

LCD side: black, yellow, green, red.

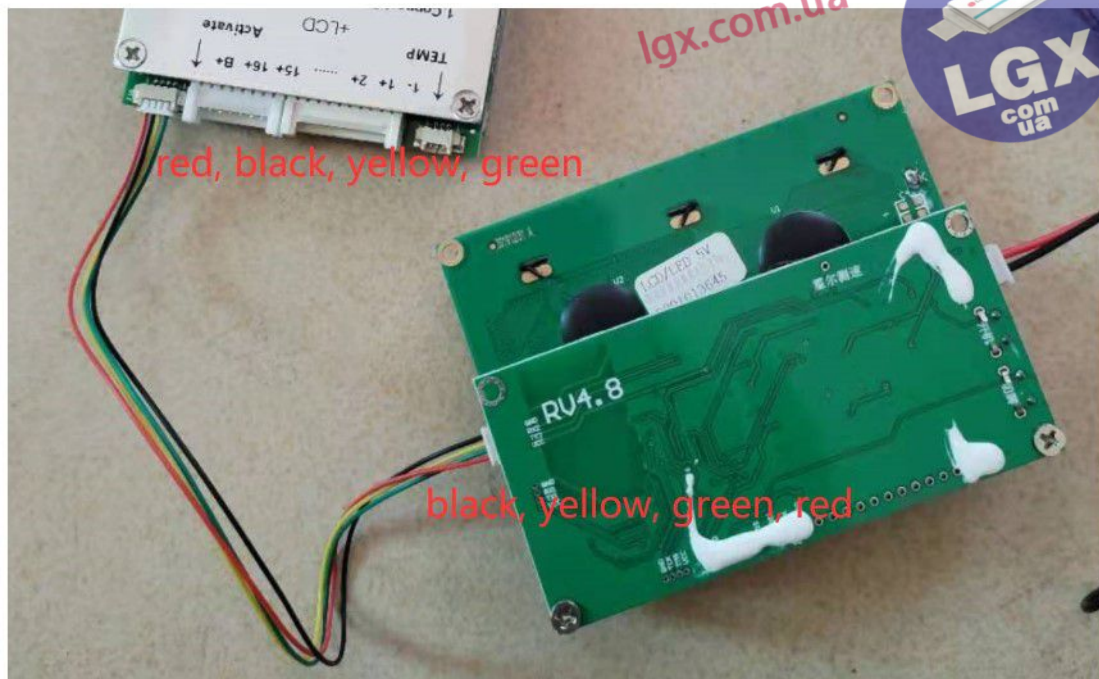

Or follow this photo.

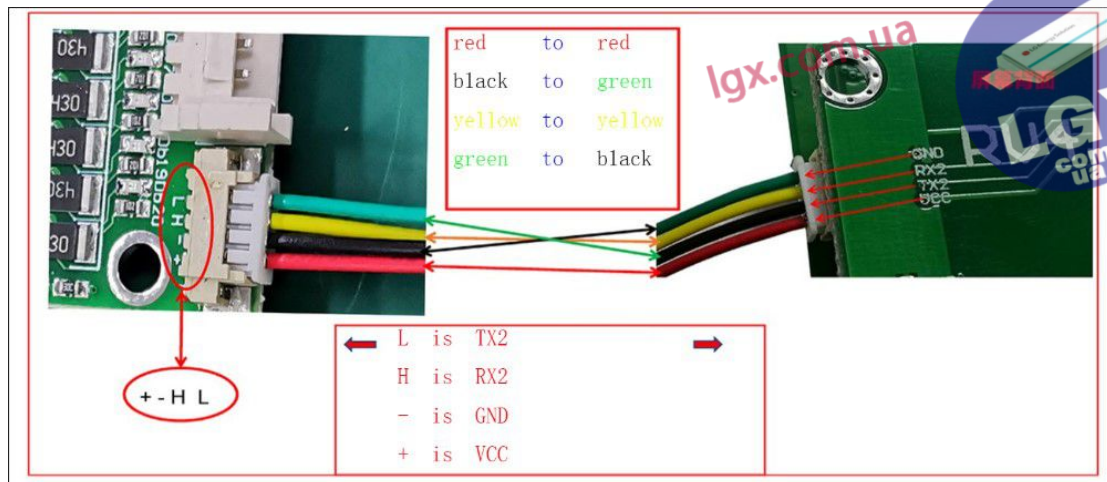

lgx.com.ua

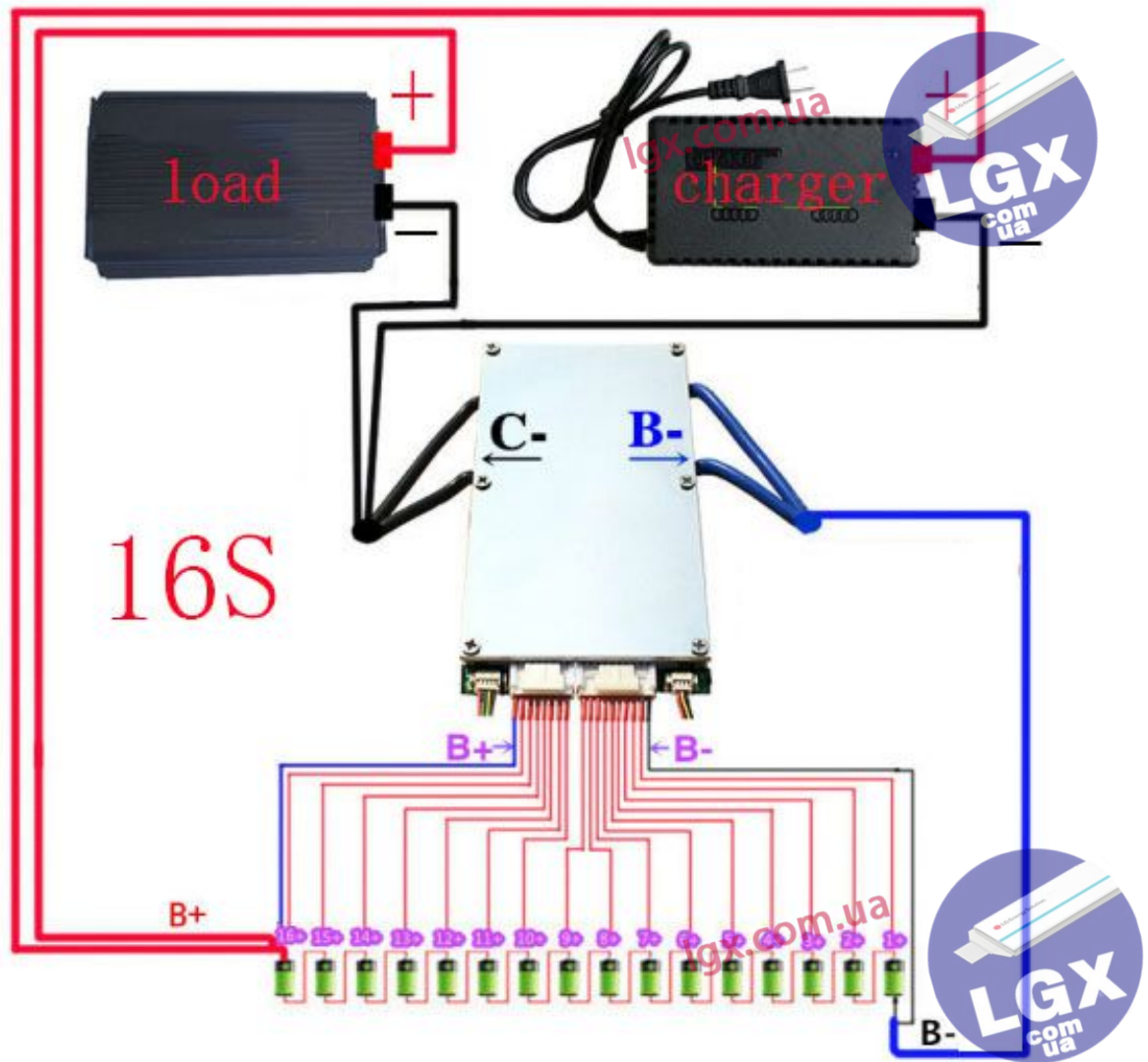

lgx.com.ua

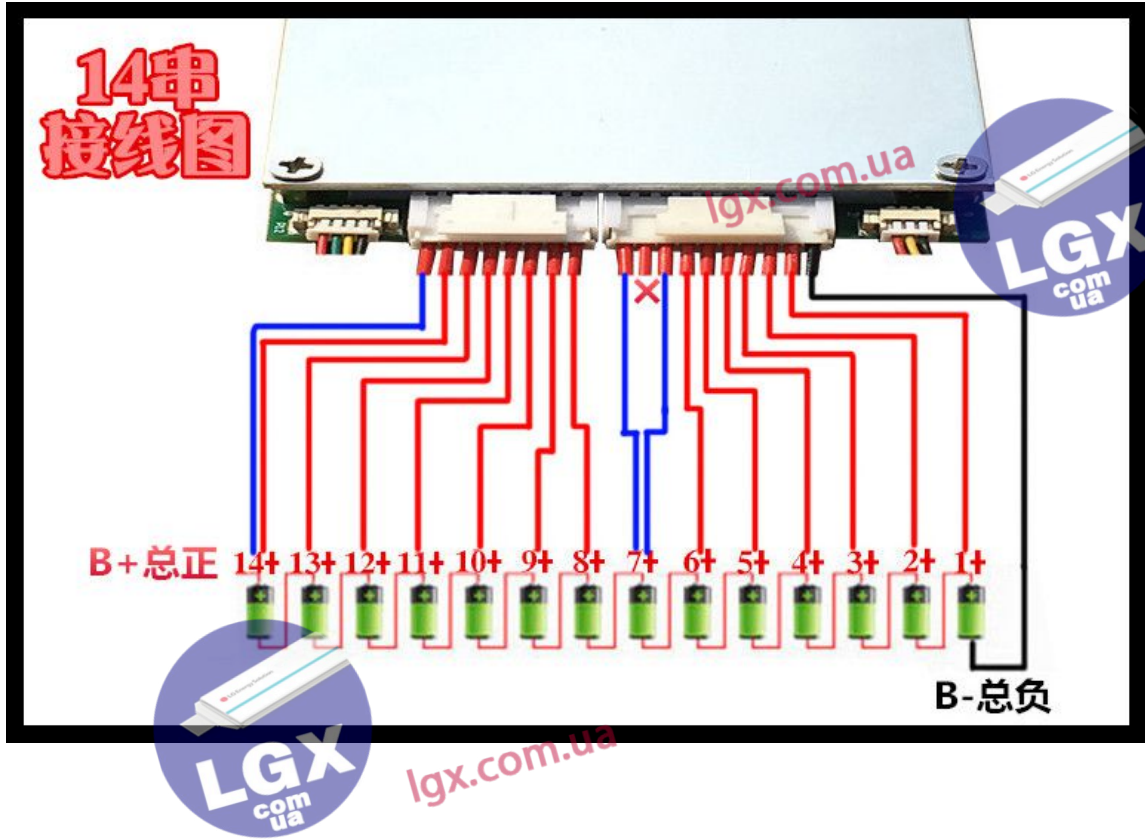
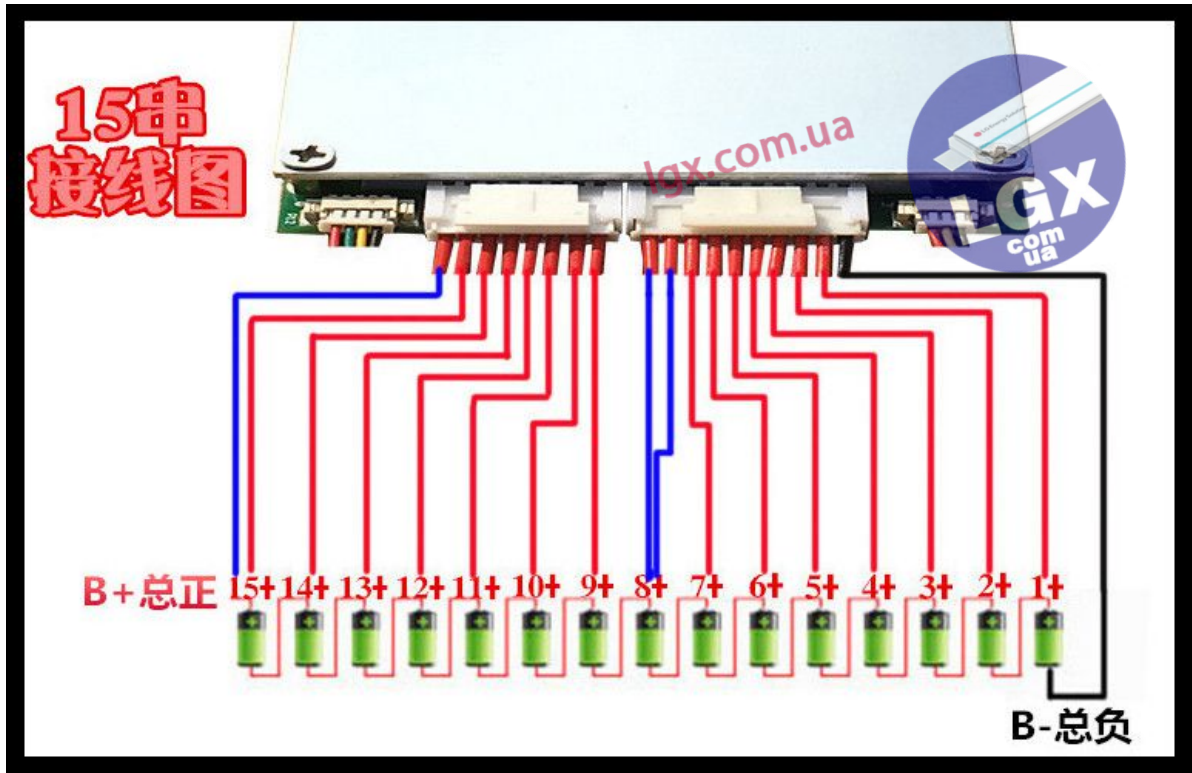

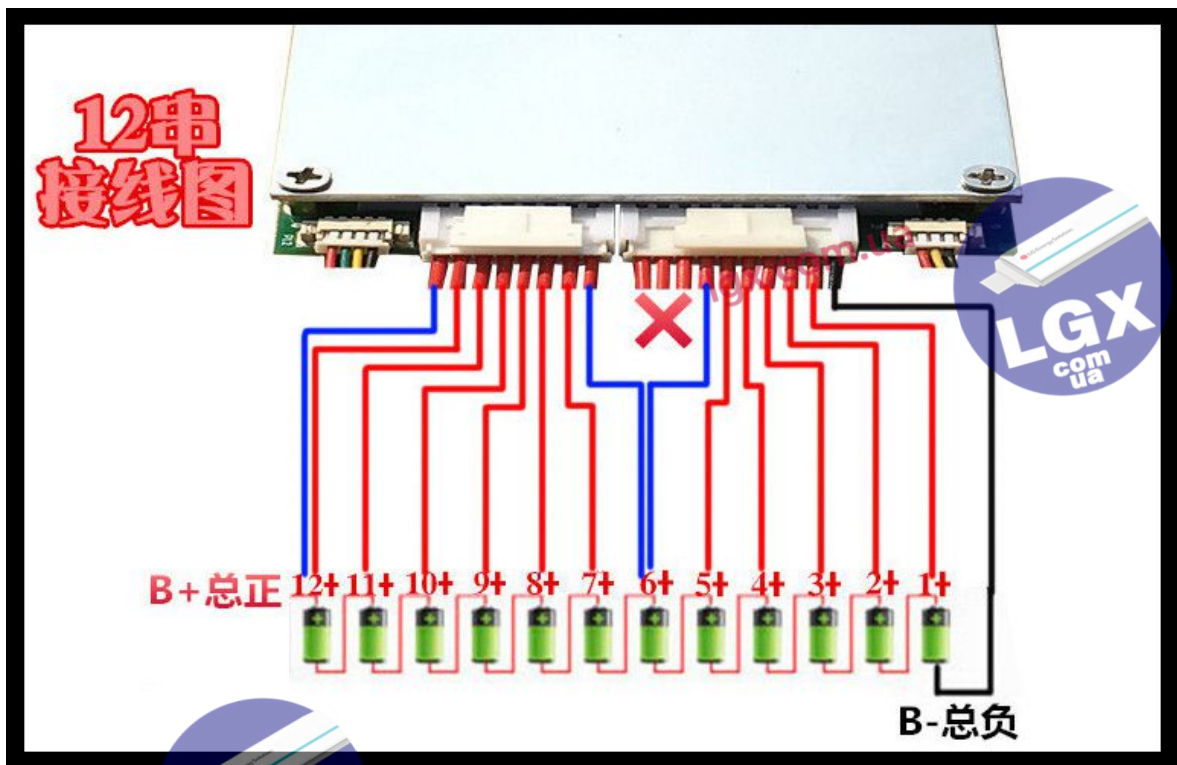
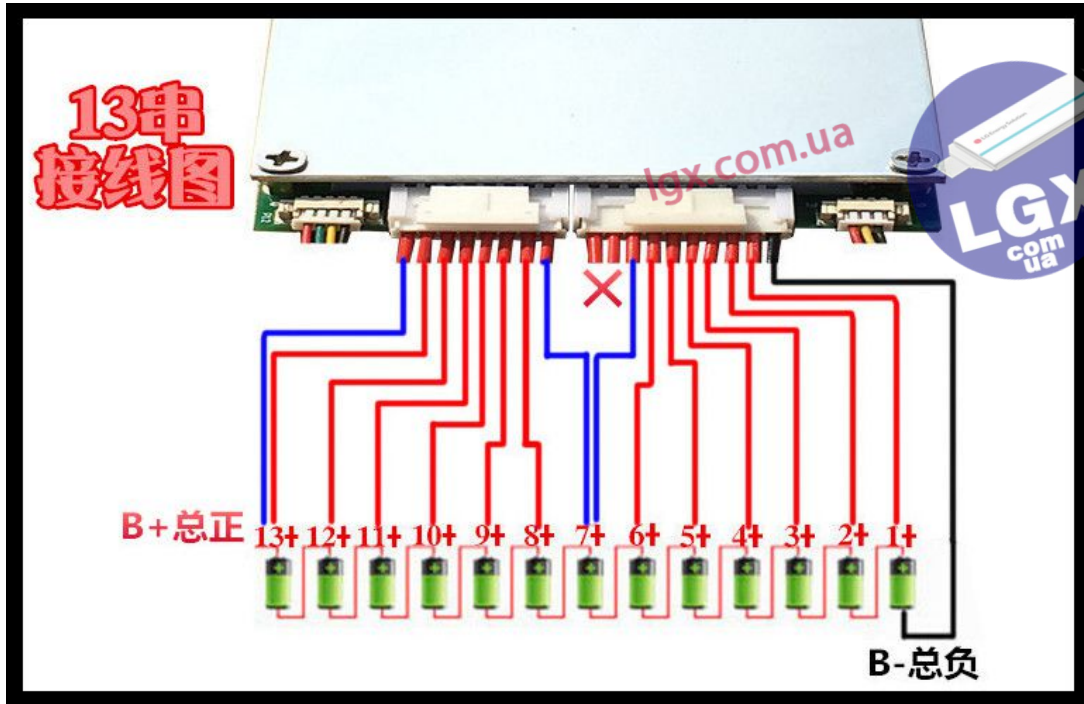

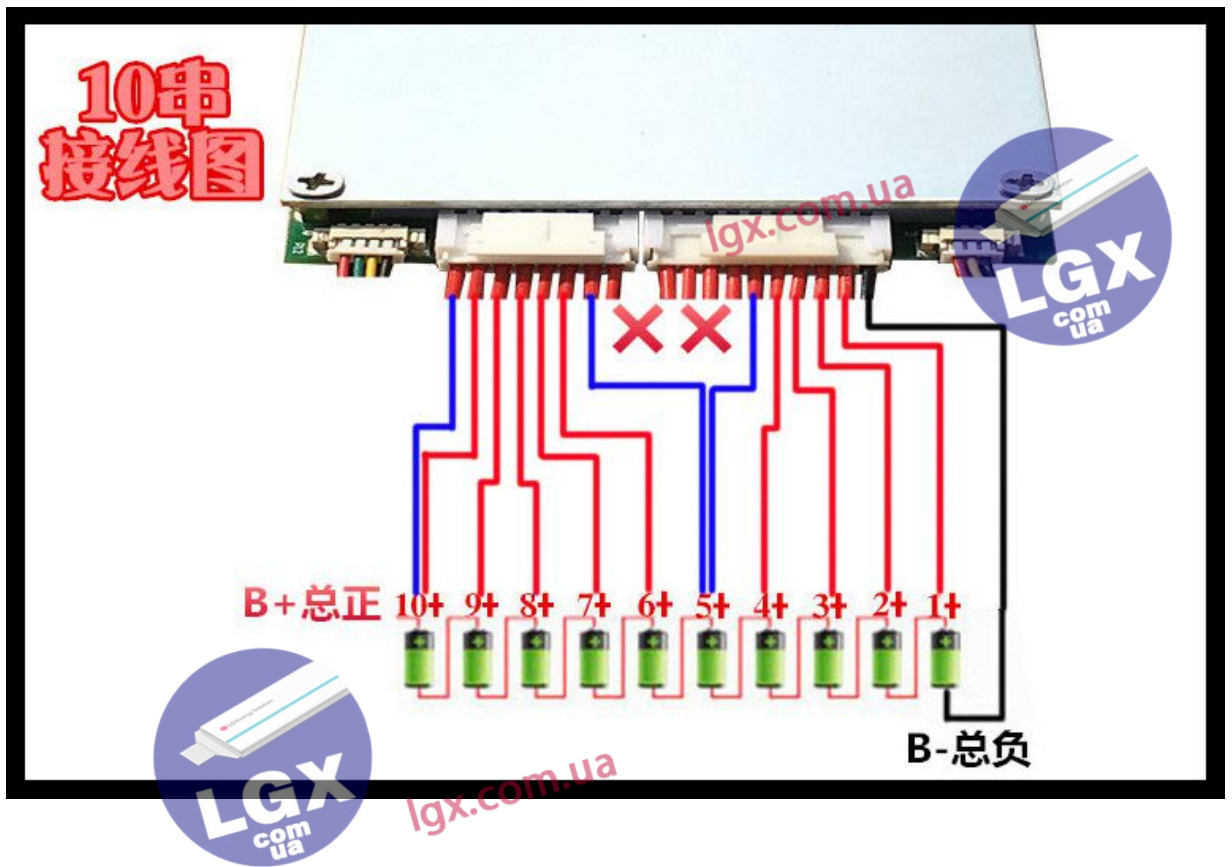
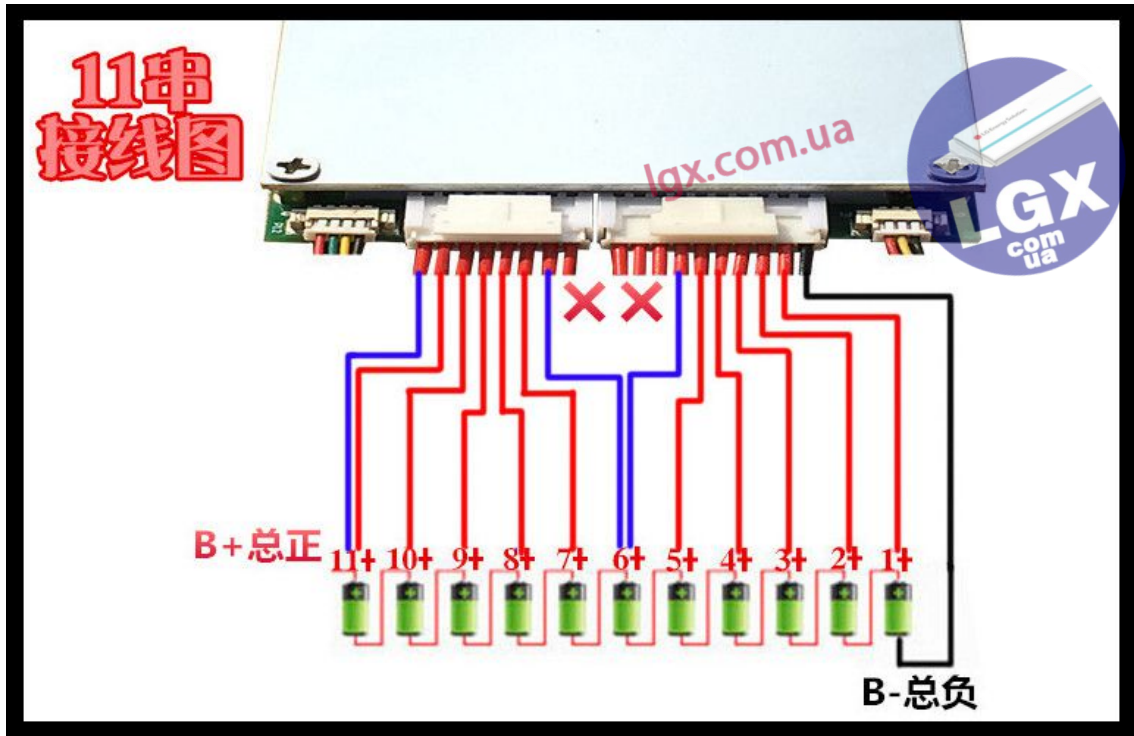

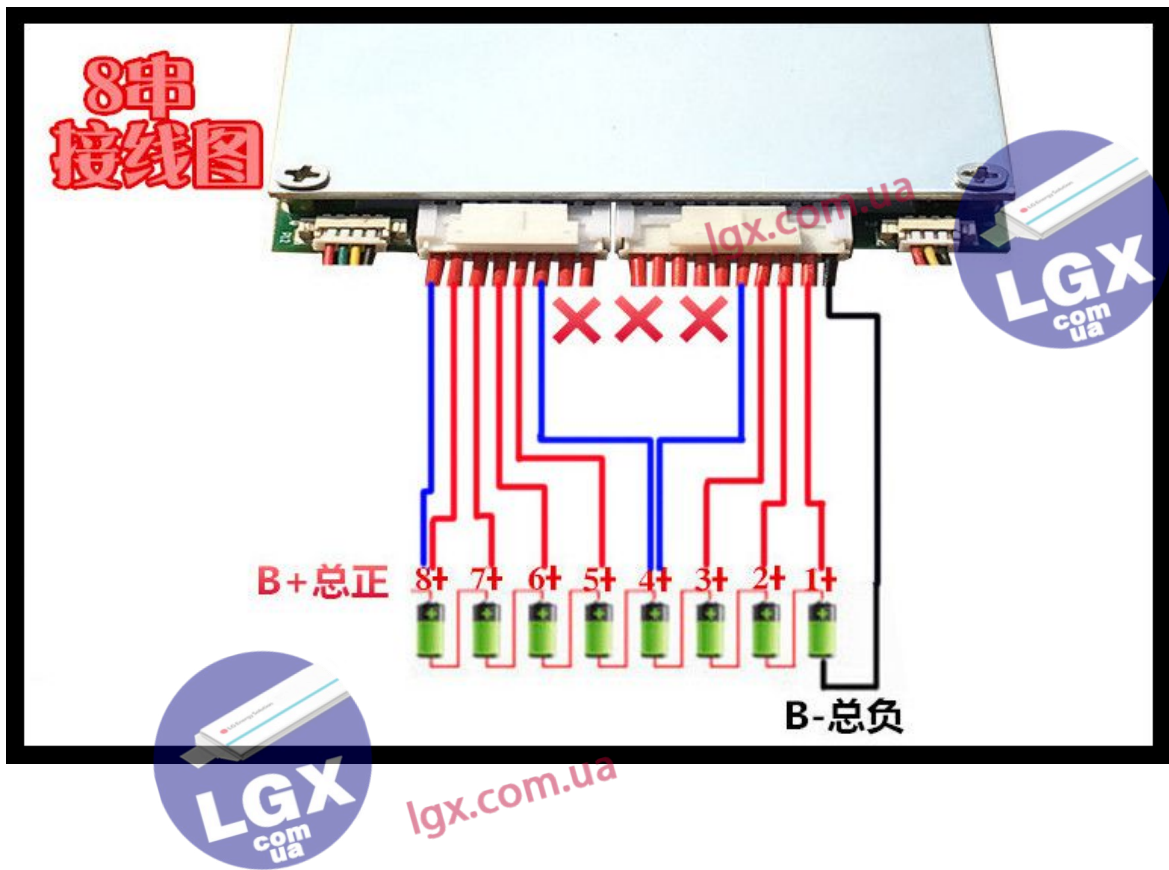
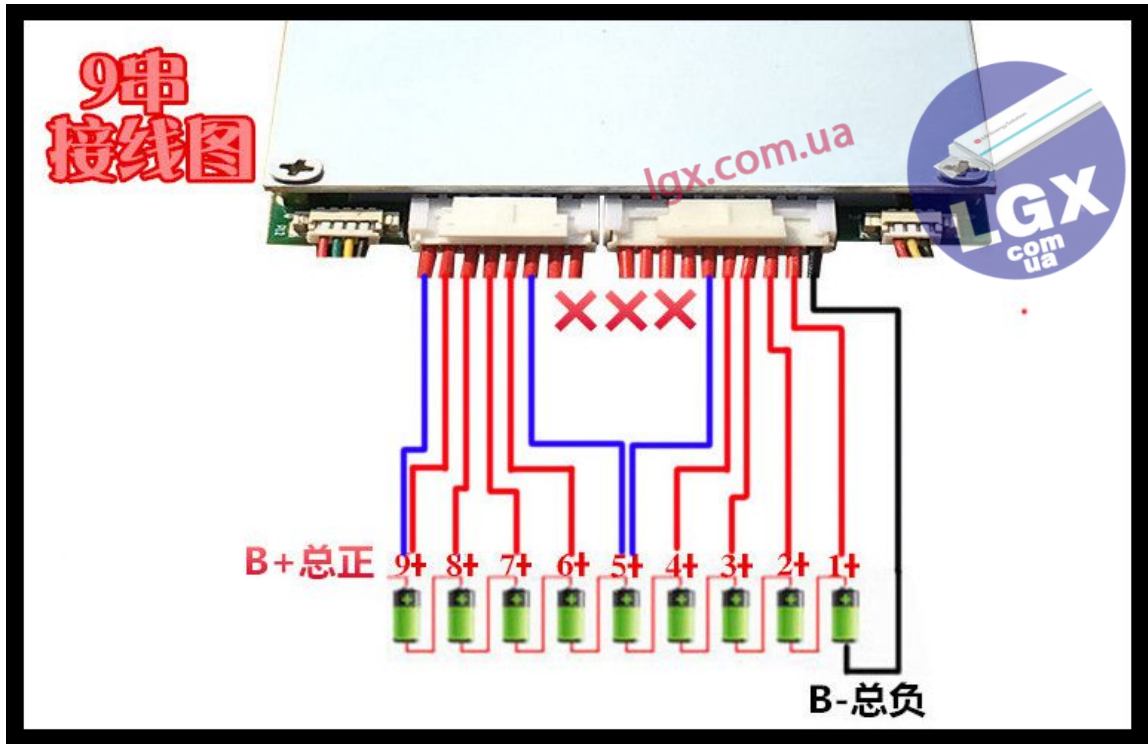

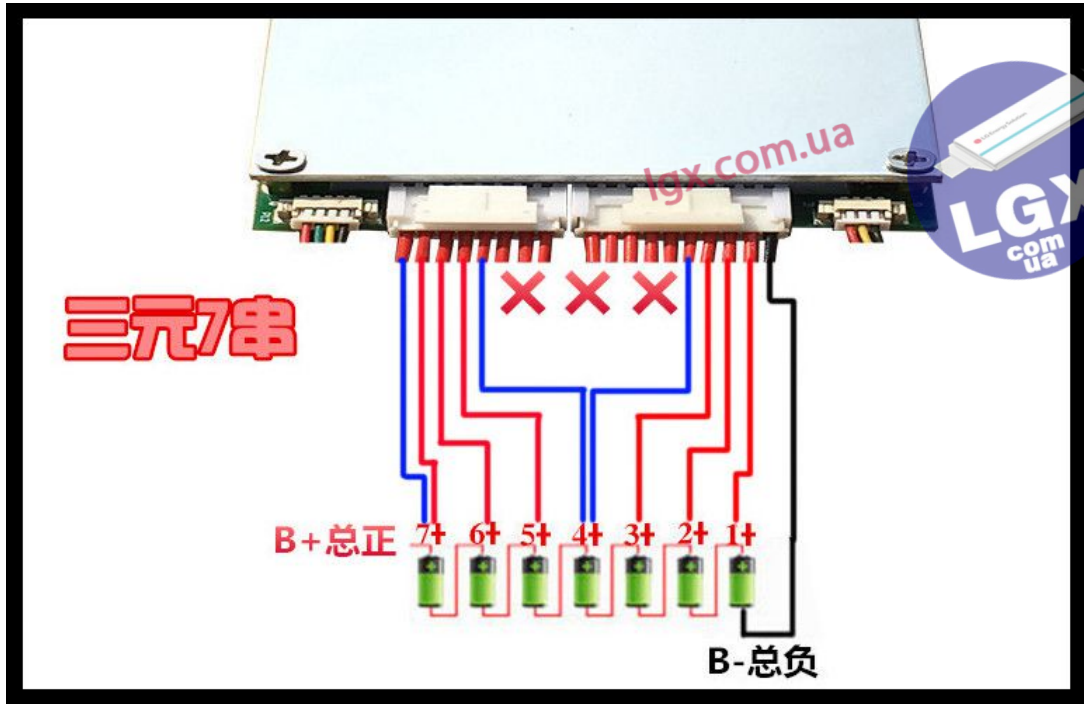

lgx.com.ua



lgx.com.ua

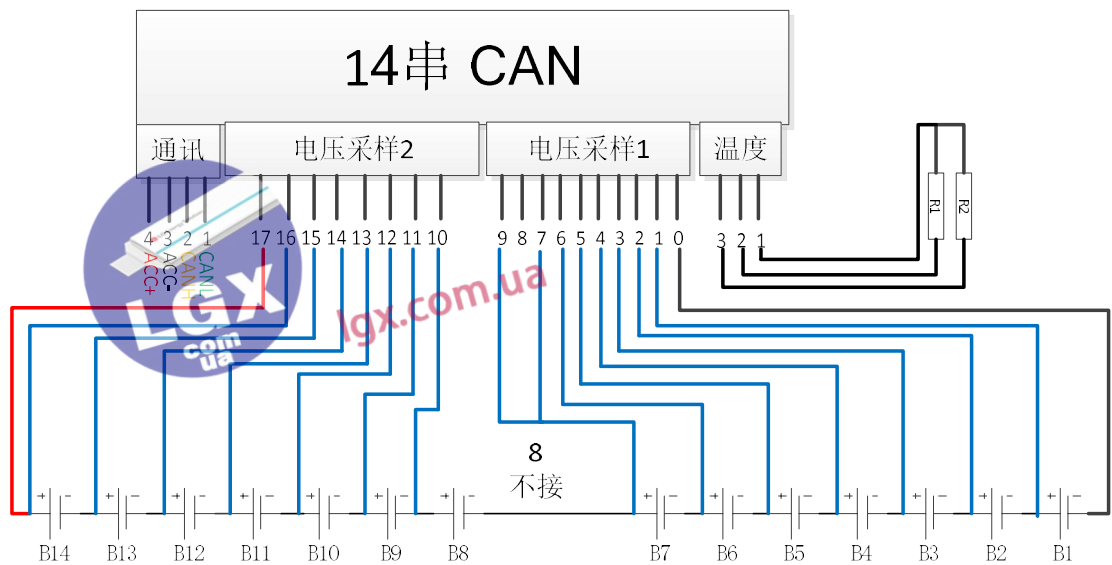
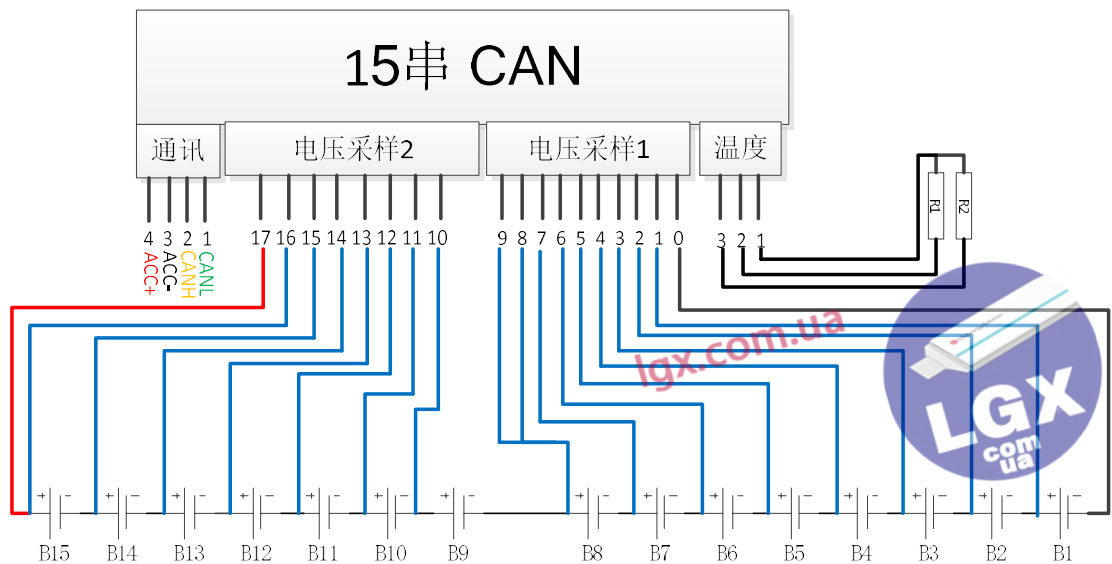
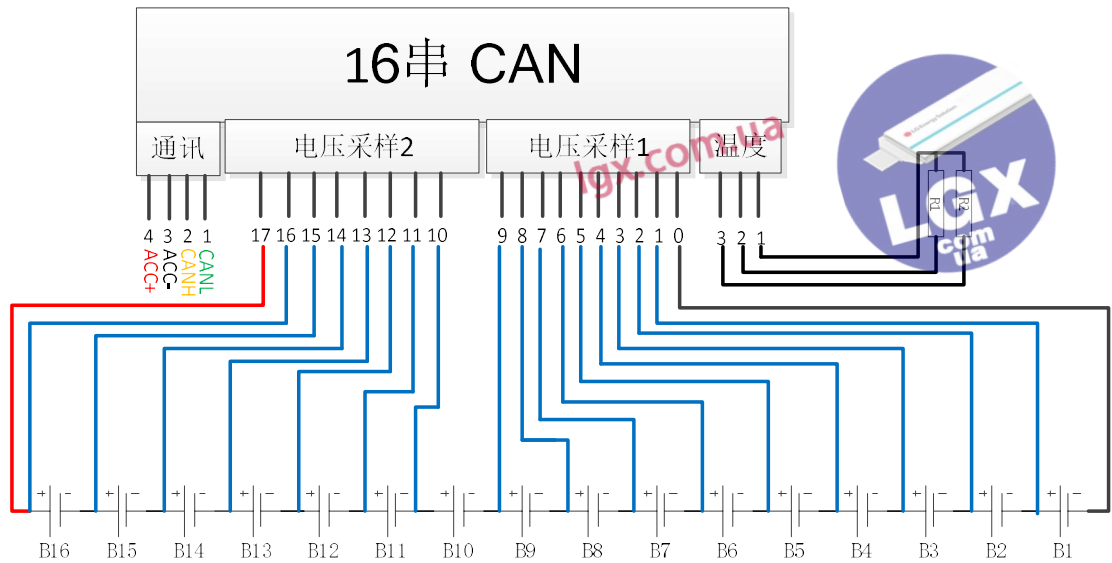

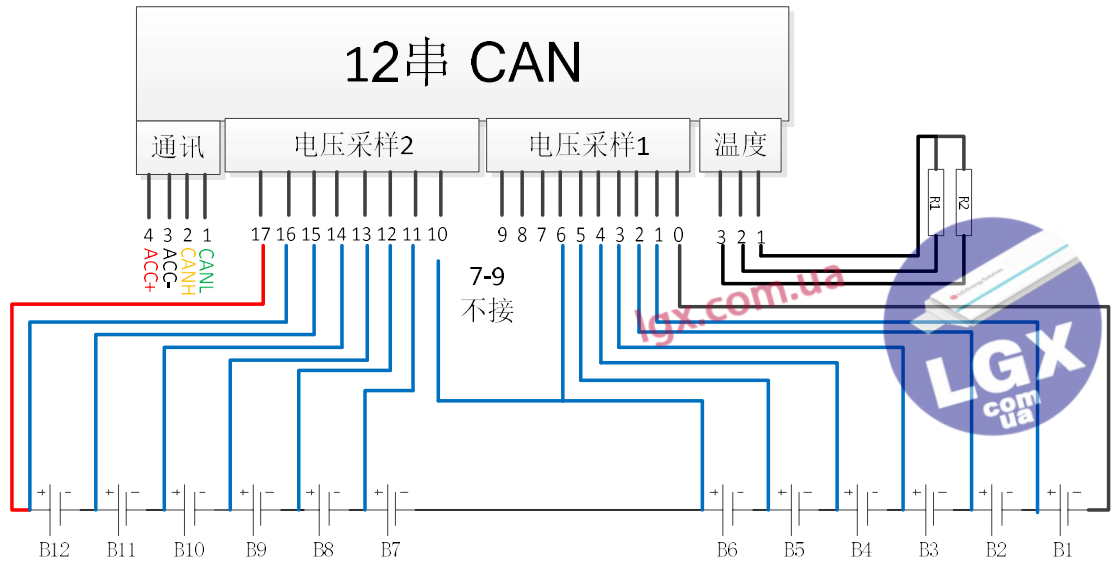
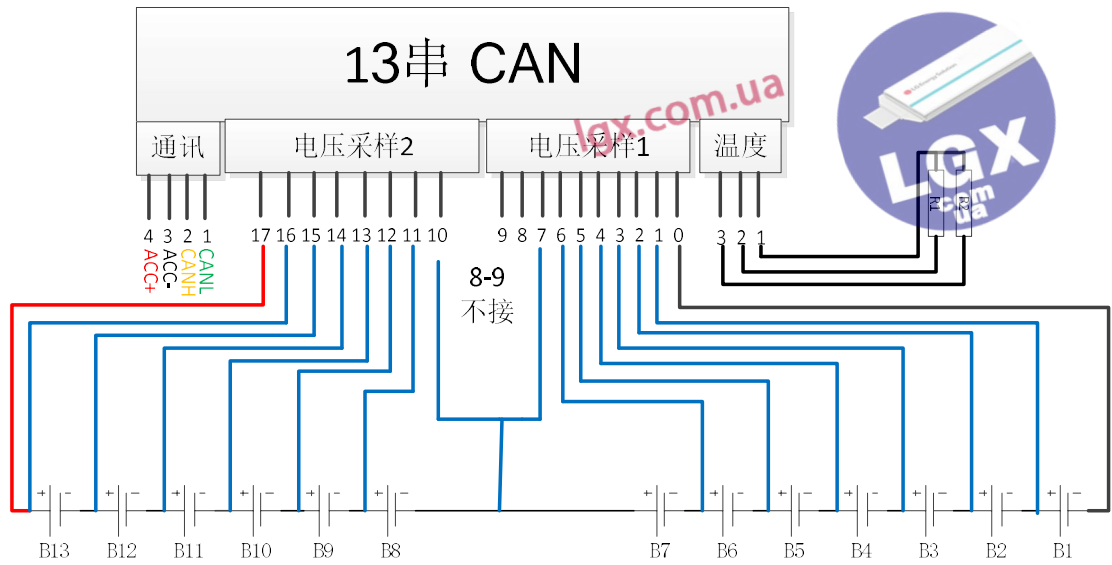

lgx.com.ua

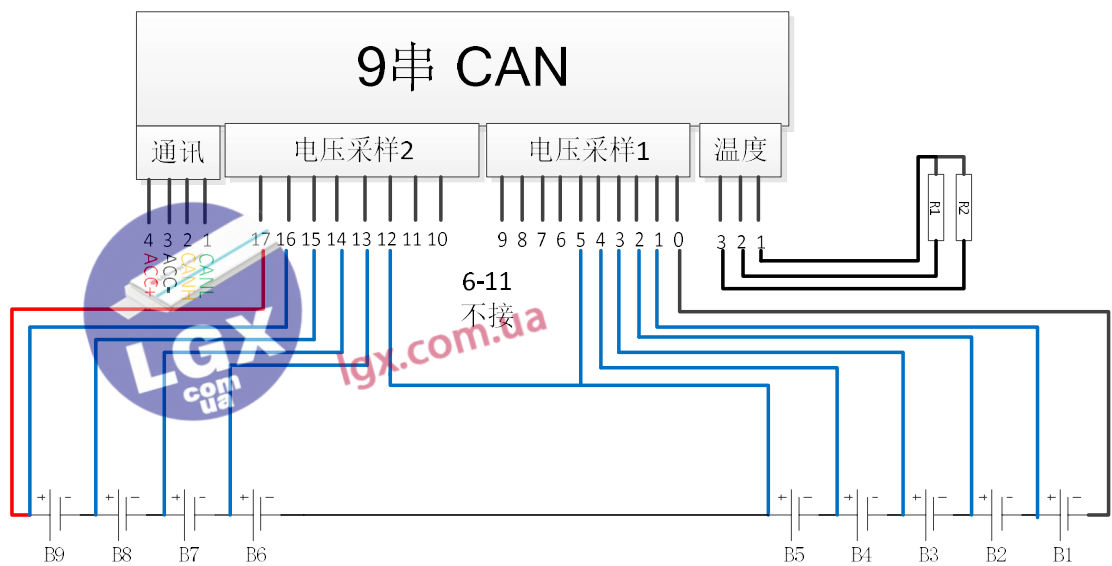
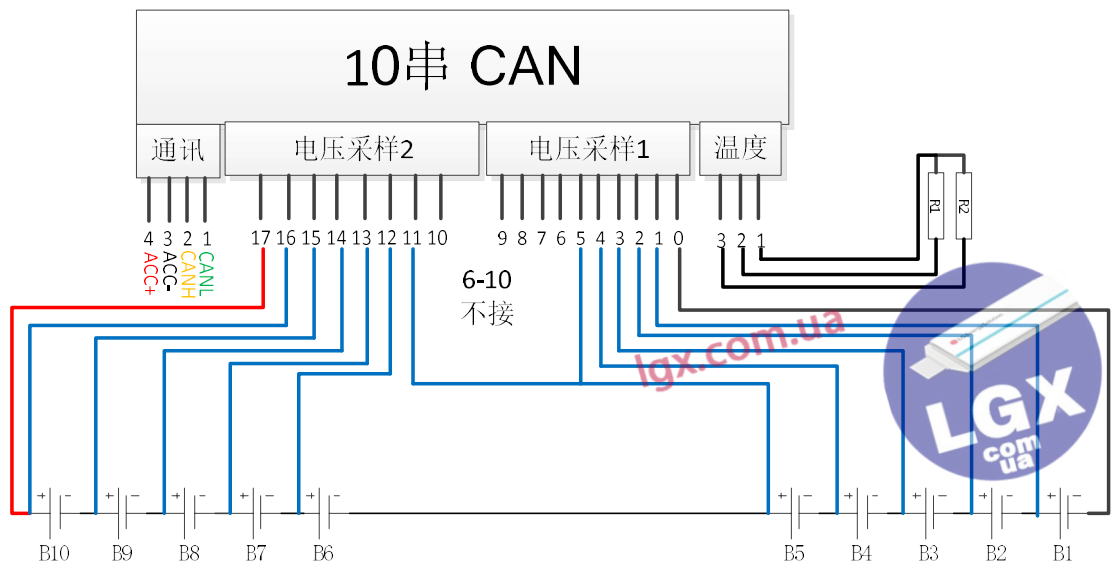
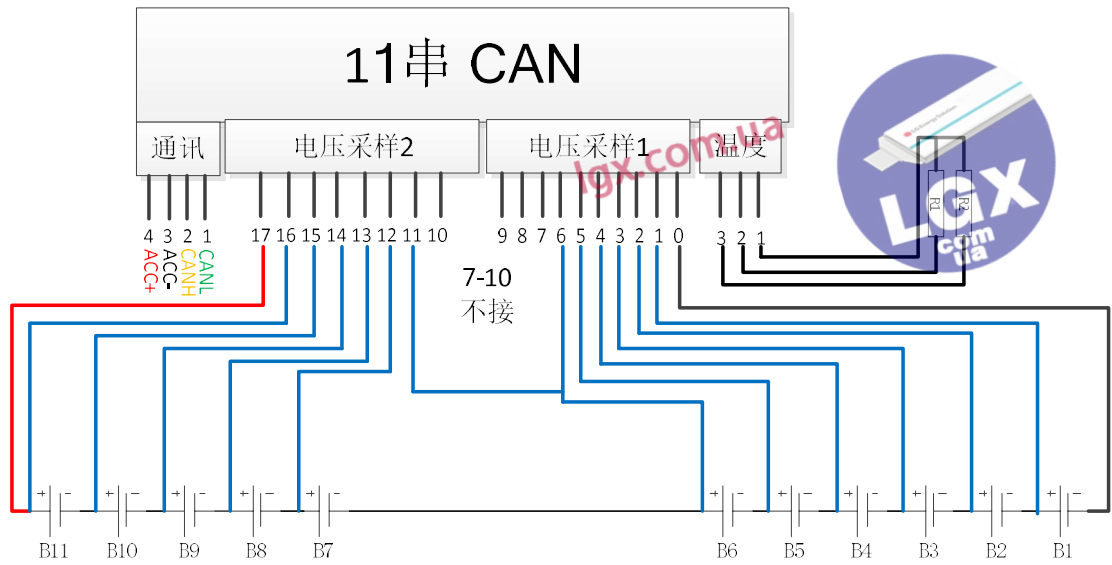

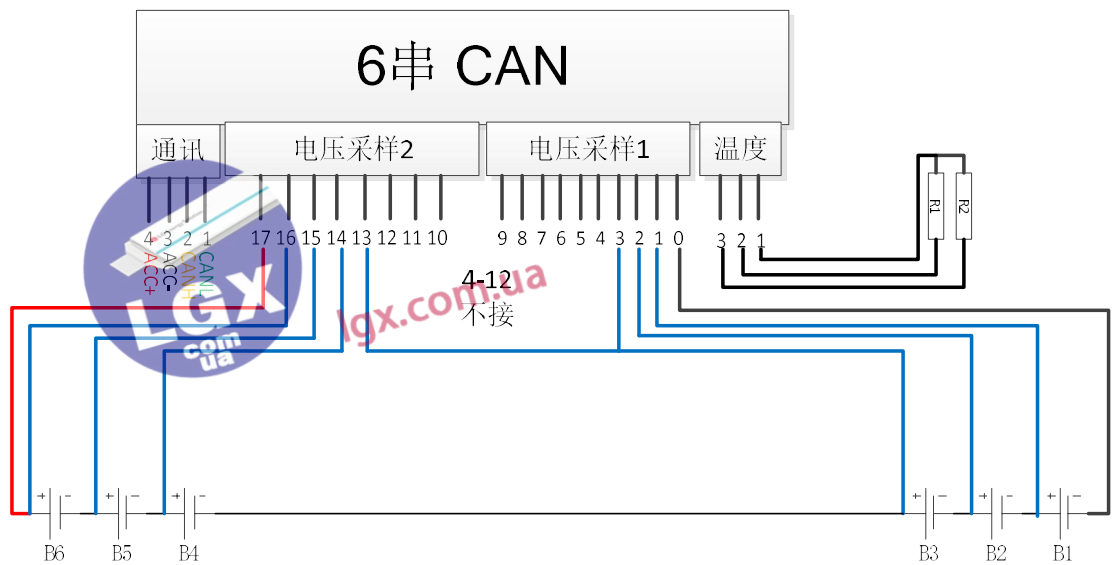
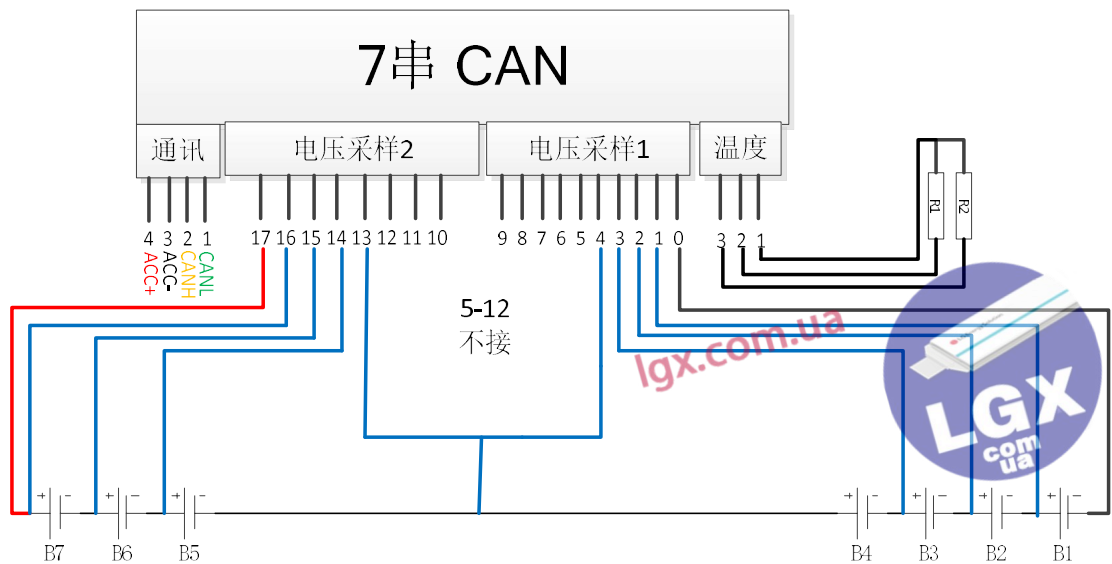
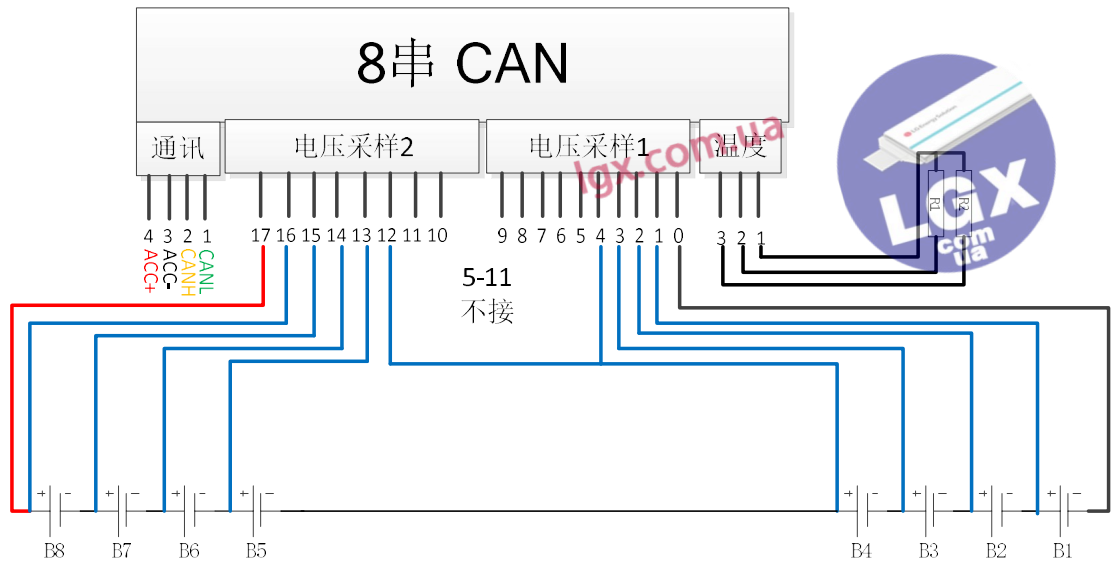

size: 140*70*17mm

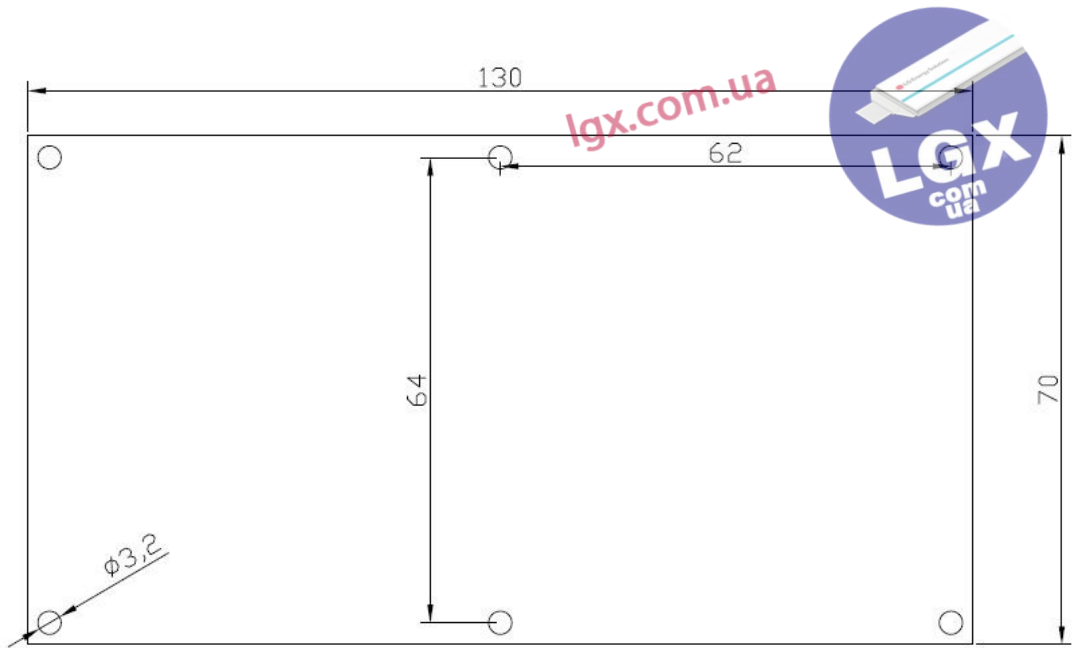

lgx.com.ua



lgx.com.ua