

ANT-BMS-20-T Wiring diagram

The ANT-BMS-20-T is an all-in-one BMS. The main functions include single-cell voltage detection, temperature detection, high-voltage detection, battery equalization, CAN/485 communication, Bluetooth communication (mobile phone APP), sleep wake-up, delayed power-off, residual power evaluation, MOS switch, etc.

- Li-ion(3.7V): 8S to 20S all can support.
- LiFePO4(3.2V): 8S to 20S all can support.
- LTO(2.4V): 10S to 20S all can support.

lgx.com.ua



ANT BMS 20S	work current	peak current
Li-ion(3.7V): 8S to 20S	50A	80A
LiFePo4(3.2V): 8S to 20S	100A	300A
LTO(2.4V): 10S to 20S	160A	400A

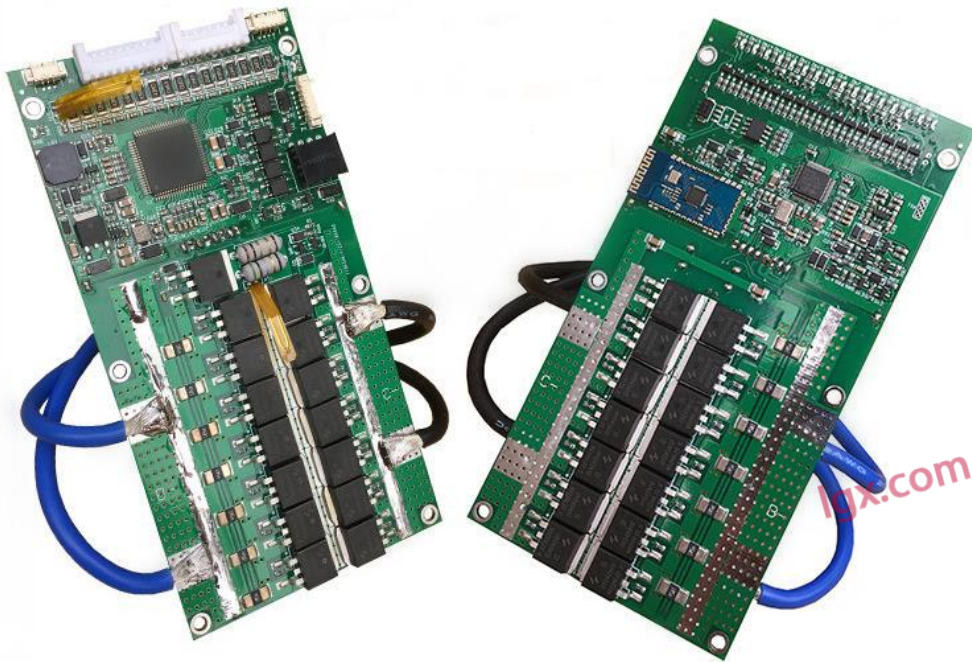

lgx.com.ua

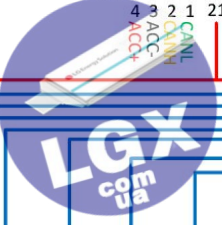
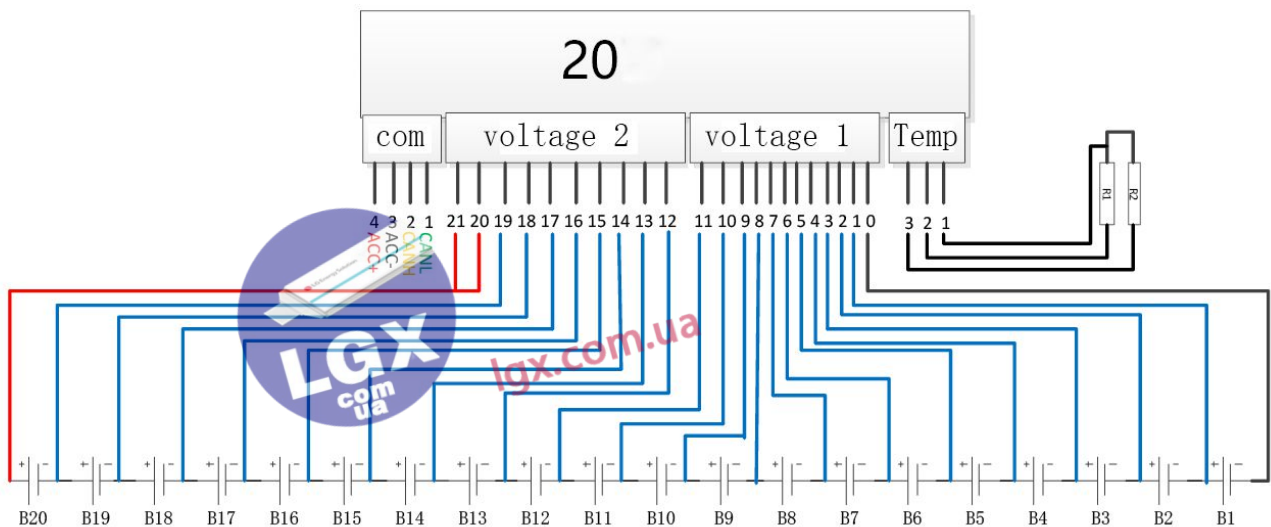

lgx.com.ua

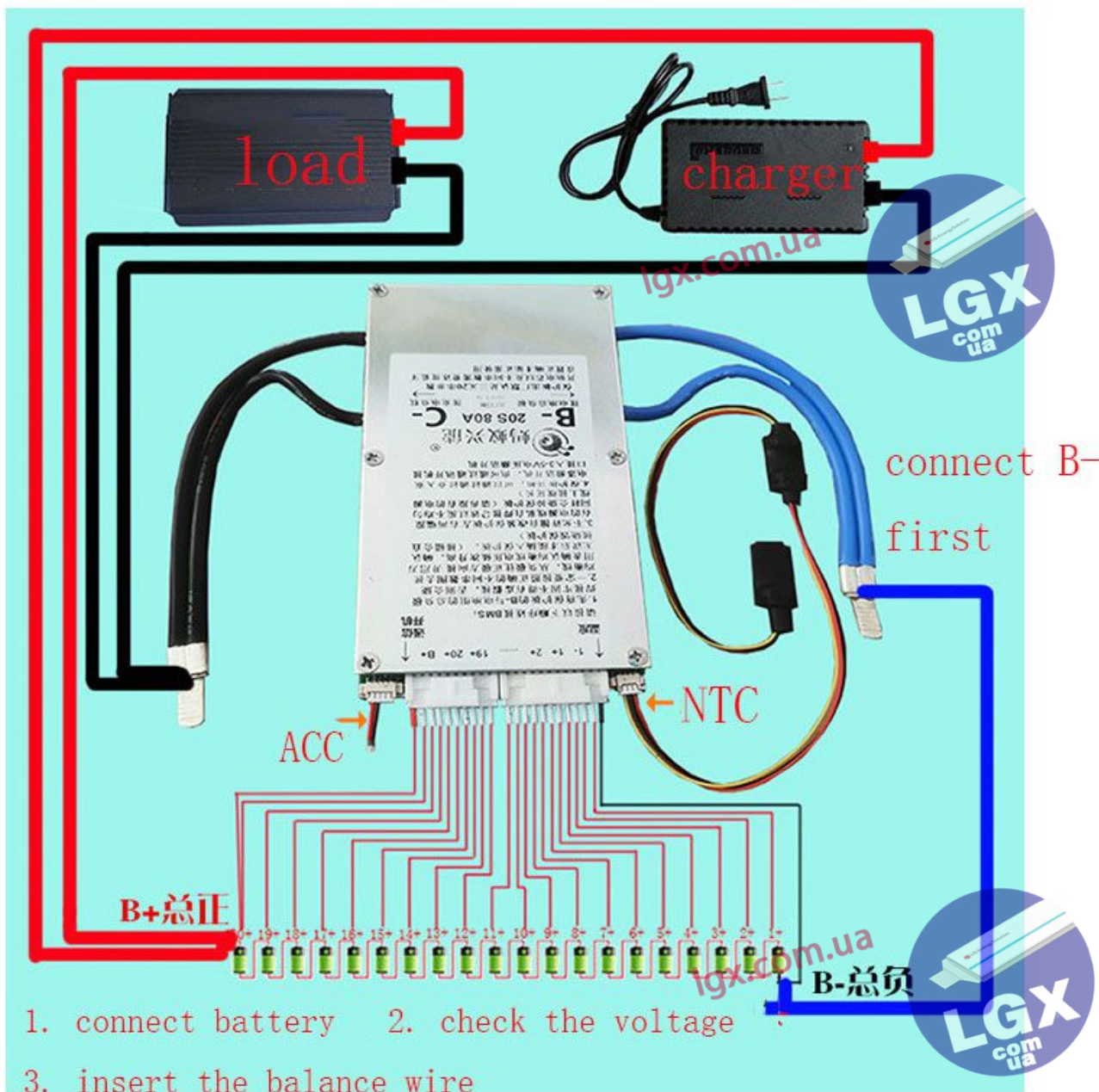

lgx.com.ua



LCD communication wiring

BMS side: red, black, yellow, green.
 LCD side: black, yellow, green, red.

lgx.com.ua

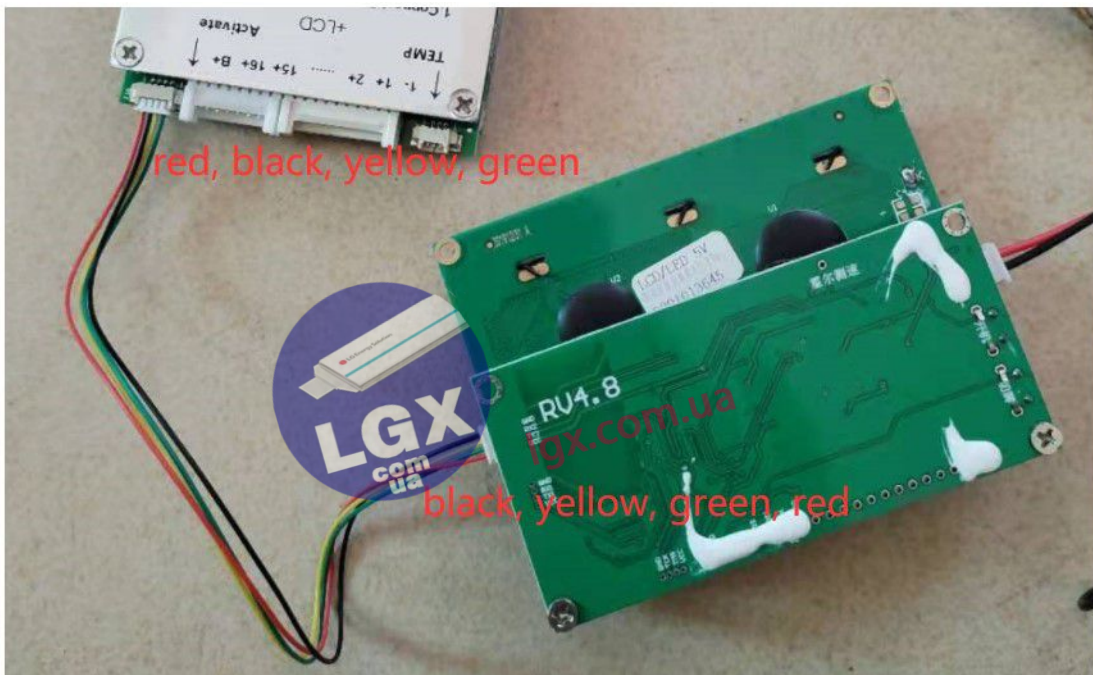

red, black, yellow, green

black, yellow, green, red



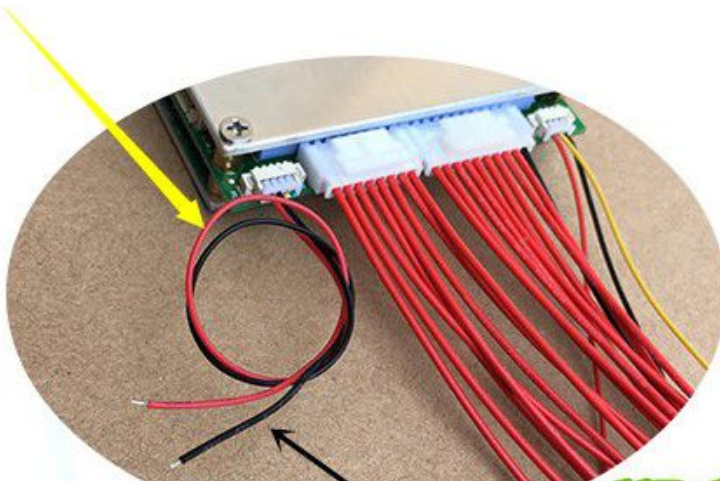

lgx.com.ua

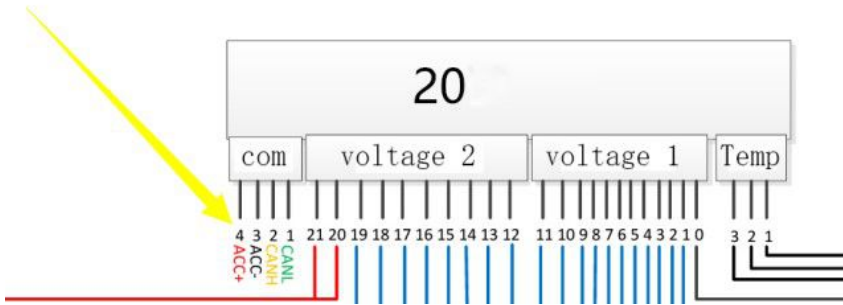

CAN	name	description
1	CAN_L	CAN bus low signal
2	CAN_H	CAN bus high signal
3	ACC-	Active signal negative
4	ACC+	Active signal positive

lgx.com.ua



RS485	name	description
1	485B	RS485_B signal
2	485A	RS485_A signal
3	ACC-	Active signal negative
4	ACC+	Active signal positive

UART	name	description
1	RXD	RXD signal for UART
2	TXD	TXD signal for UART
3	GND	GND signal for UART
4	VCC	VCC signal for UART

Note: LCD and CAN share the same port, it's decide by the software, if configure to LCD, press the key in LCD also can active the BMS.

This BMS have two method to active(power on)

1. Use charger to charge the BMS, can active the BMS.
2. Use the active signal. Add 3V to 5V voltage in ACC signal. Then can power on the BMS. Suggestion use the voltage of one cell. After the BMS active, you will hear the “beep”, also find the red led is turn on. (add voltage, just 2 seconds then can active, then can disconnect the active voltage)

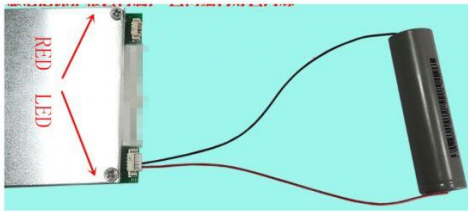

use 3V to 5V, just 2 seconds, then can active BMS, then can disconnect the active voltage

lgx.com.ua

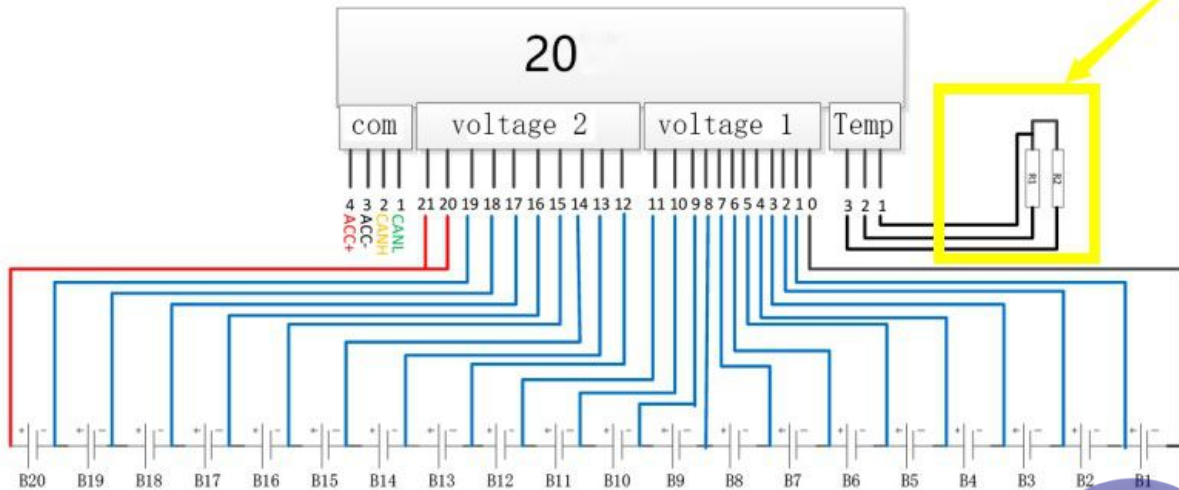

There have two temperature sensor.

lgx.com.ua



	name	description
1	GND	The GND of NTC
2	T1	The positive of T1
3	T2	The positive of T2



lgx.com.ua

外置温度传感器接线说明:



Up to 2 external temperature sensors can be connected,
The temperature sensor can also be disconnected. If the temperature sensor is not connected, the software displays **-30 degrees** by default.

After the temperature sensor is connected, use a heat-shrinkable tube to set up the insulation (as shown below), and the back is fixed with double-sided tape.

T1 and T2 are placed in different locations of the battery pack to detect the temperature.



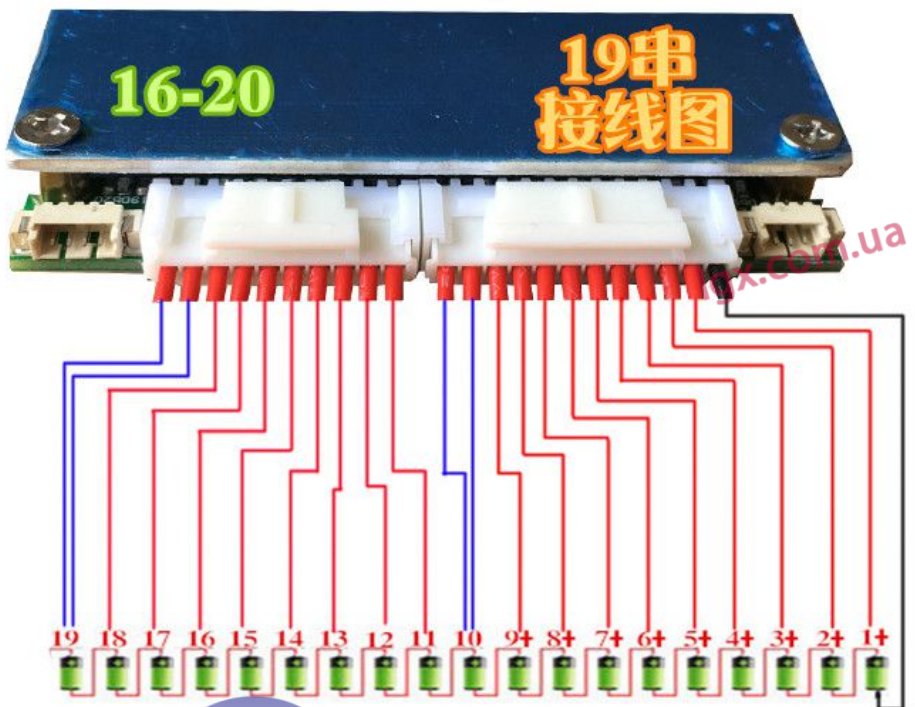
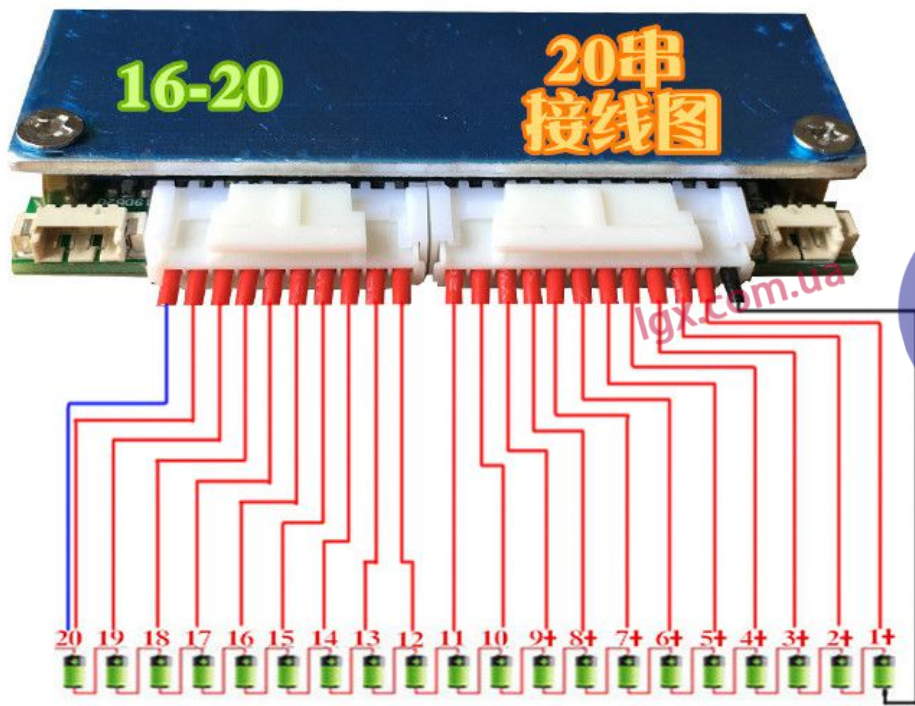

lgx.com.ua

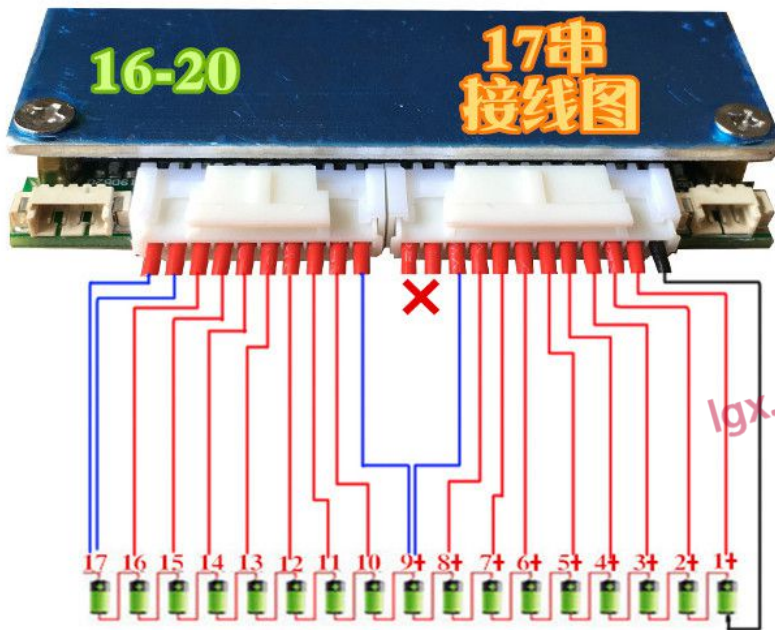
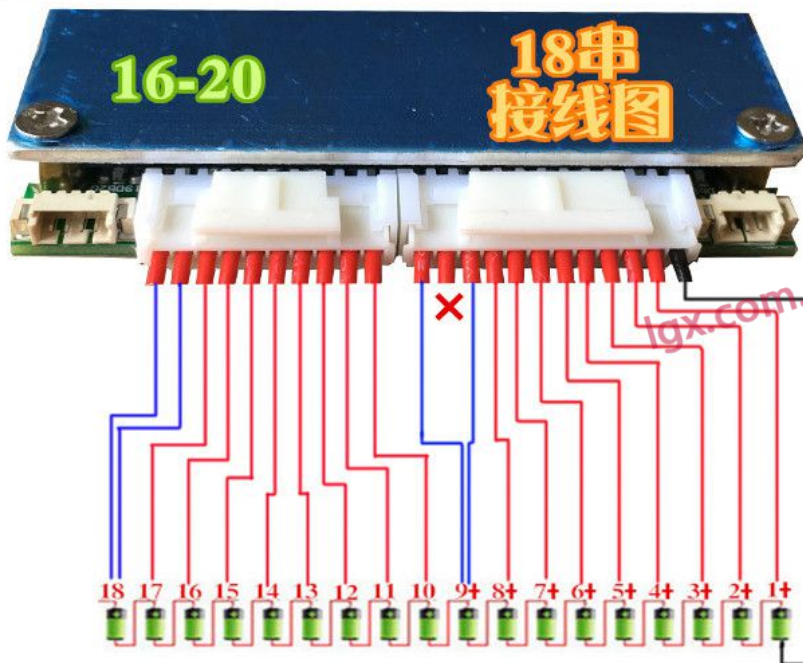

lgx.com.ua

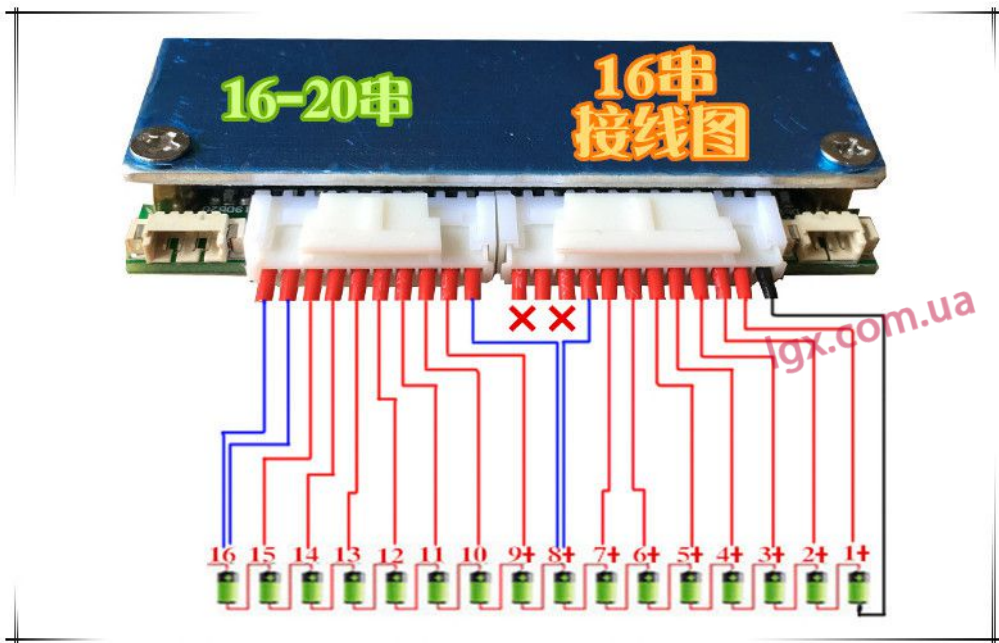

lgx.com.ua

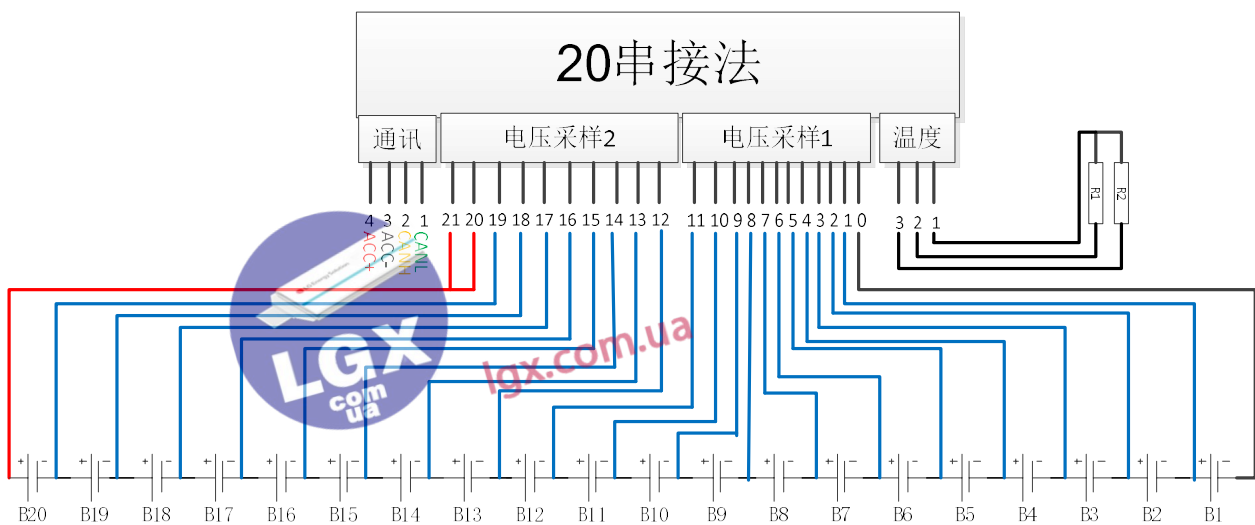

19S wiring diagram: short 10 and 11

19串接法

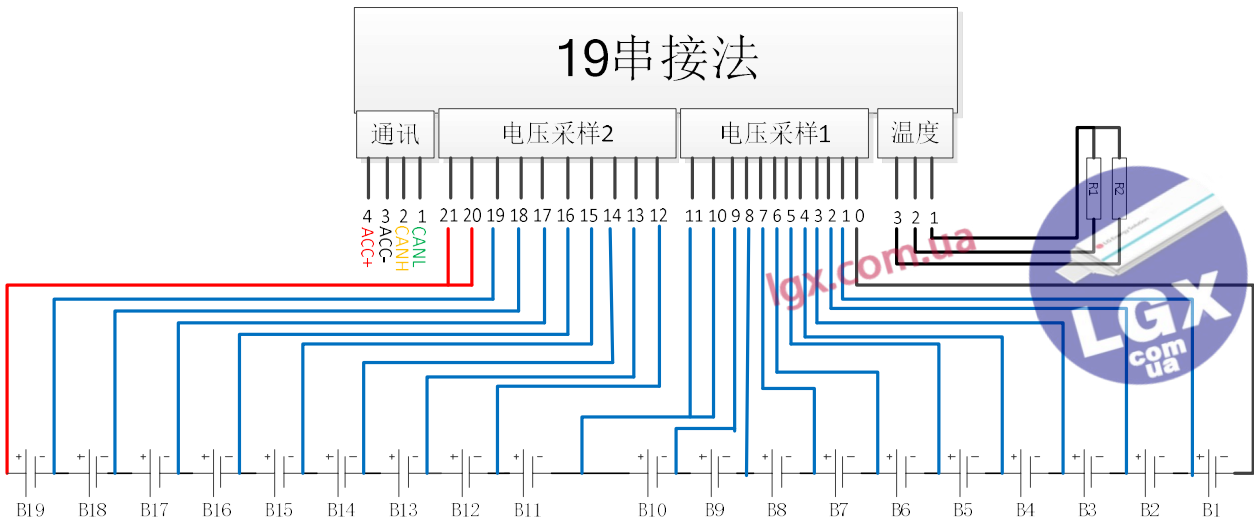

18S wiring diagram: do not use 10.

18串接法

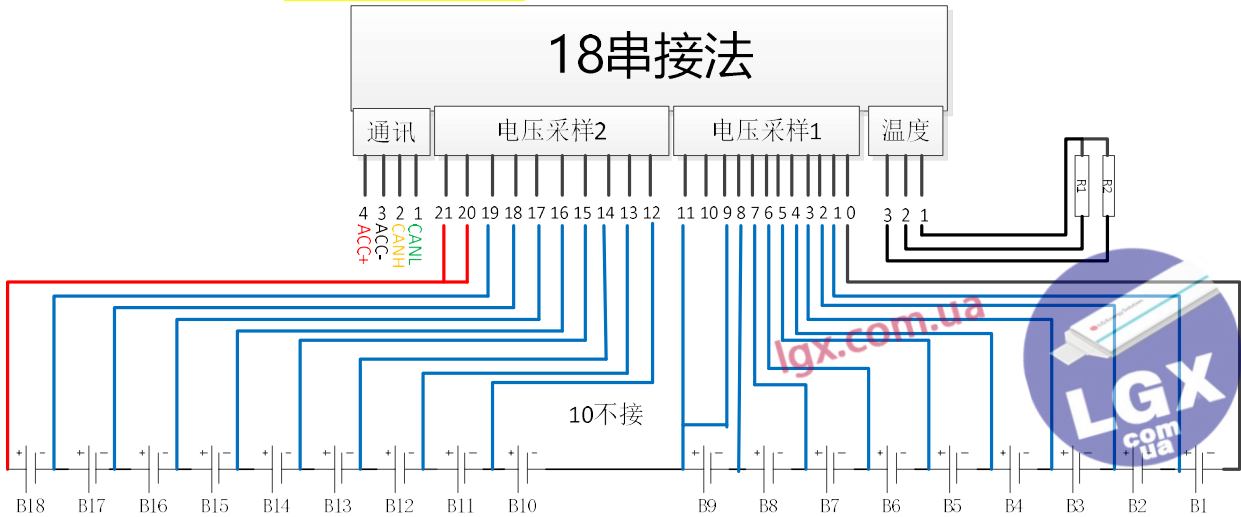

17S wiring diagram: do not use 10 to 11.

17串接法

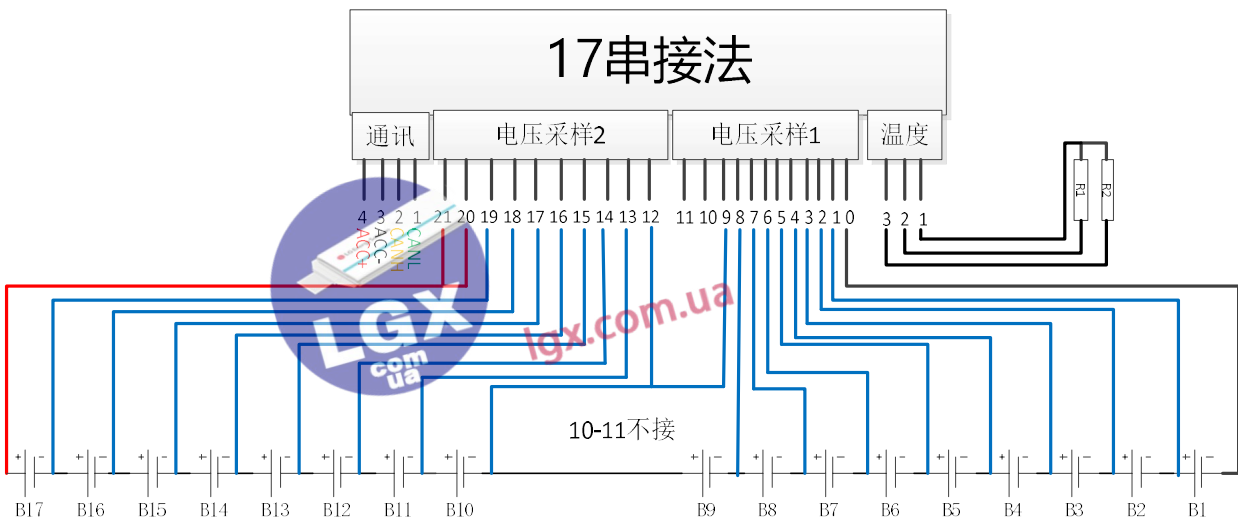

16S wiring diagram: do not use 9 to 11.

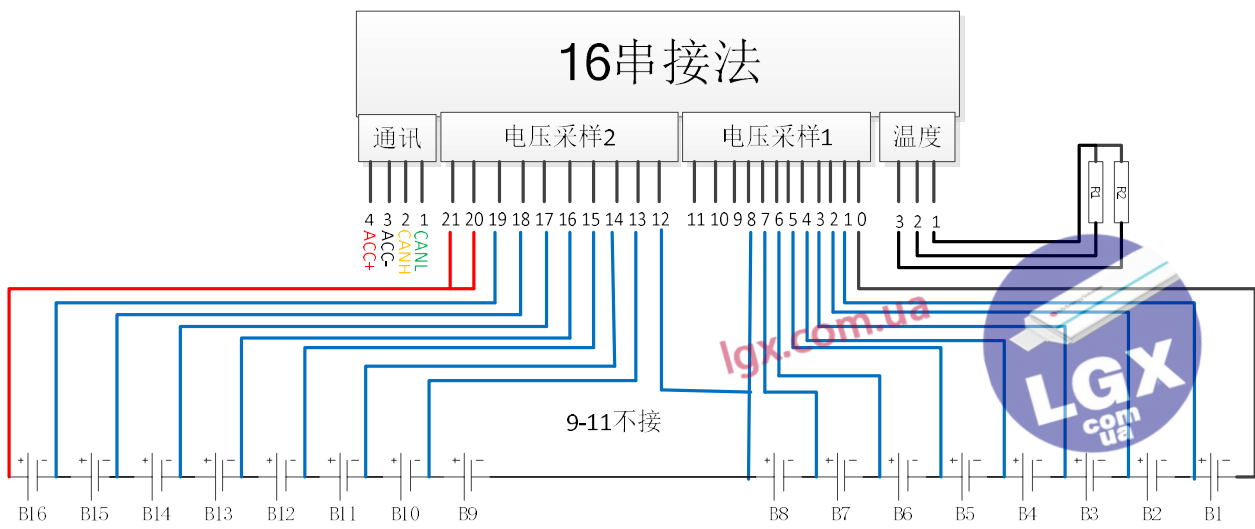

15S wiring diagram: do not use 9 to 12.

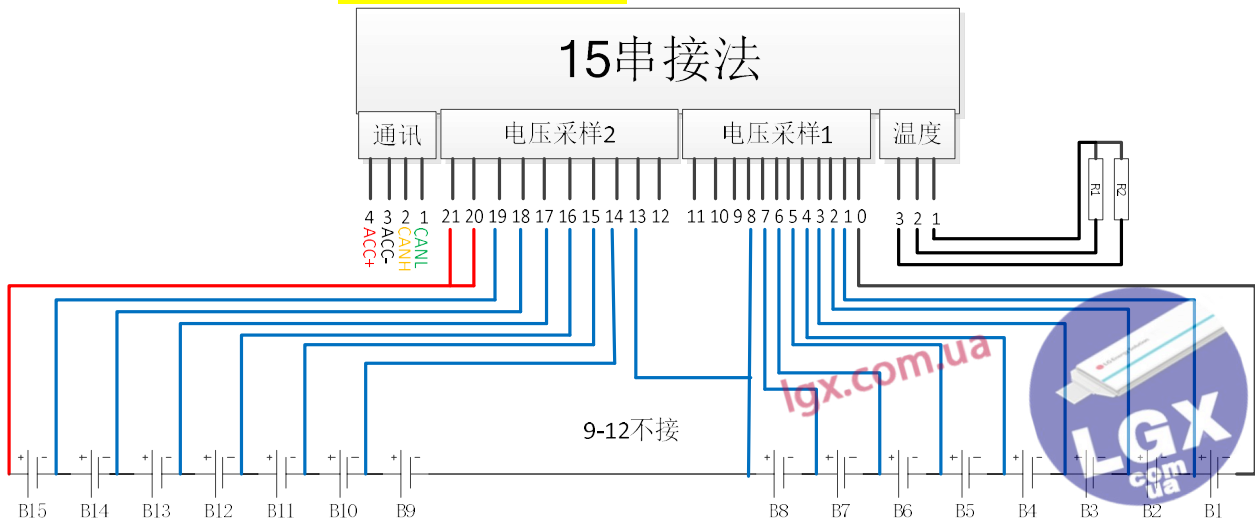

14S wiring diagram: do not use 8 to 12.

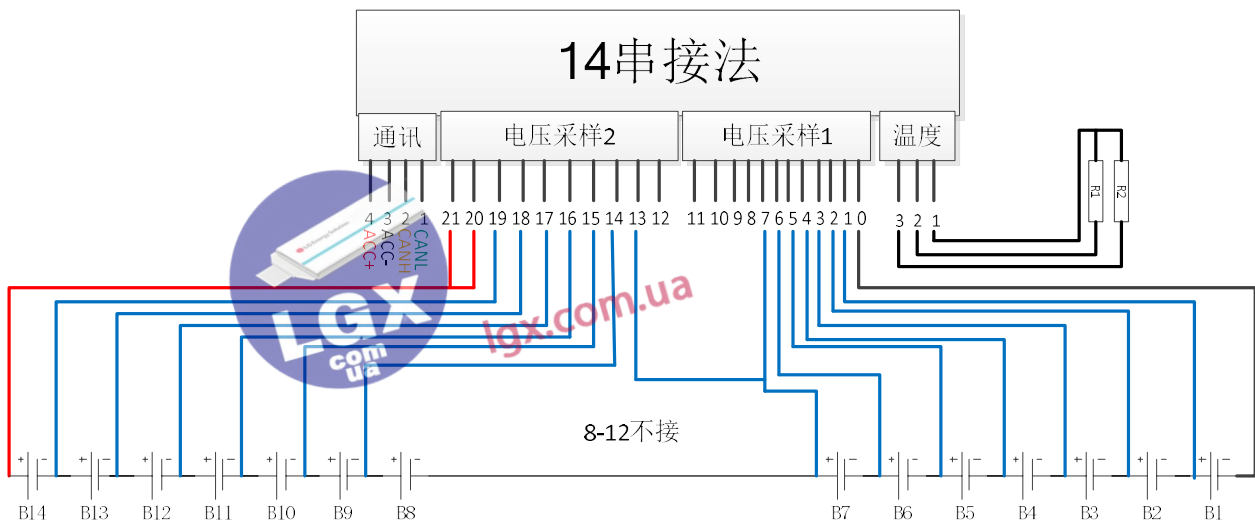

13S wiring diagram: do not use 8 to 13.

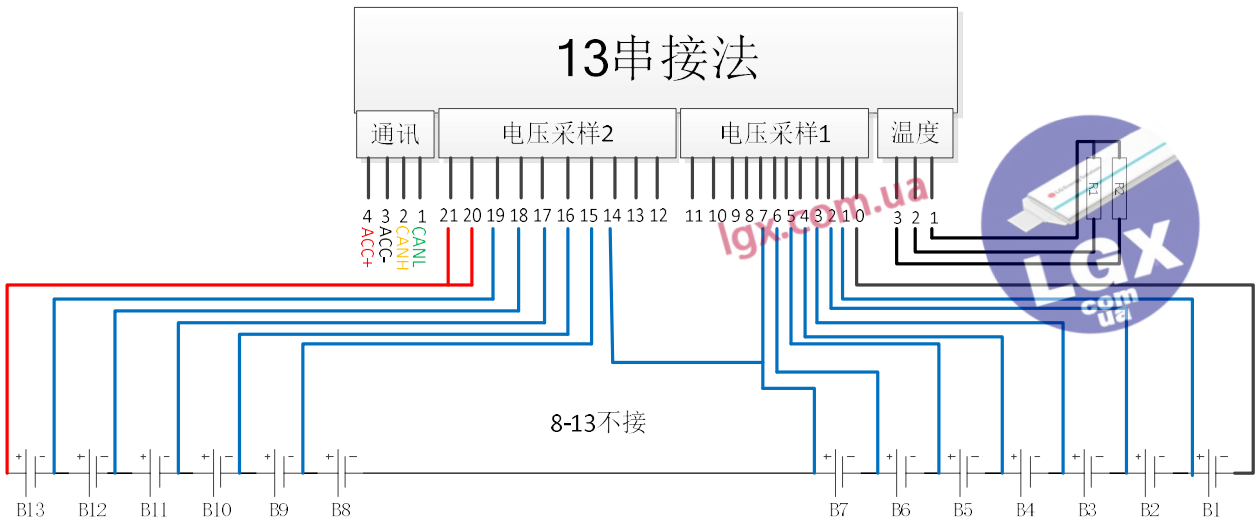

12S wiring diagram: do not use 7 to 13.

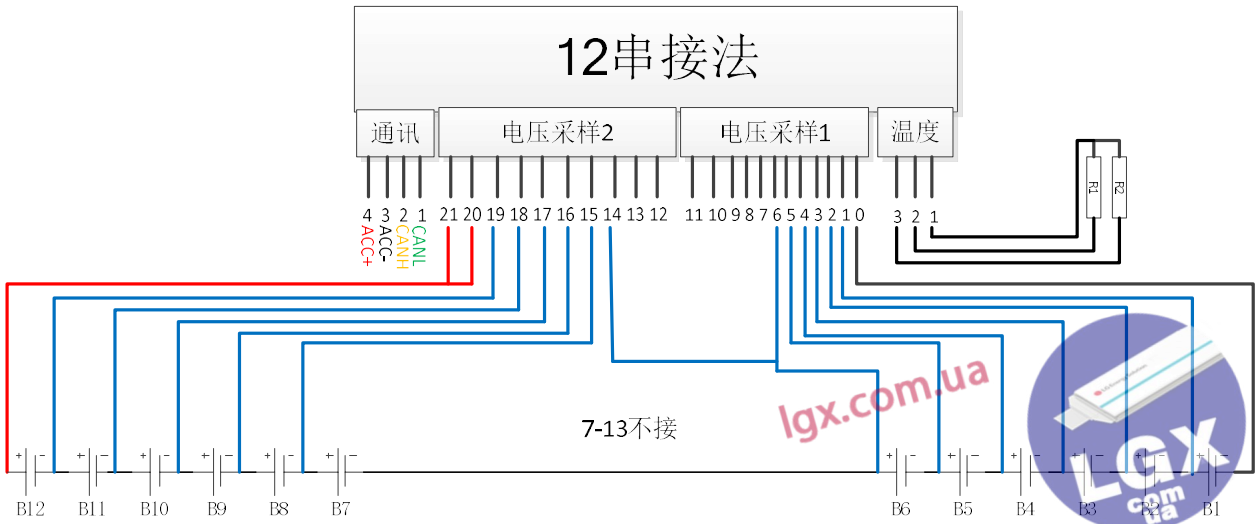

11S wiring diagram: do not use 7 to 14.

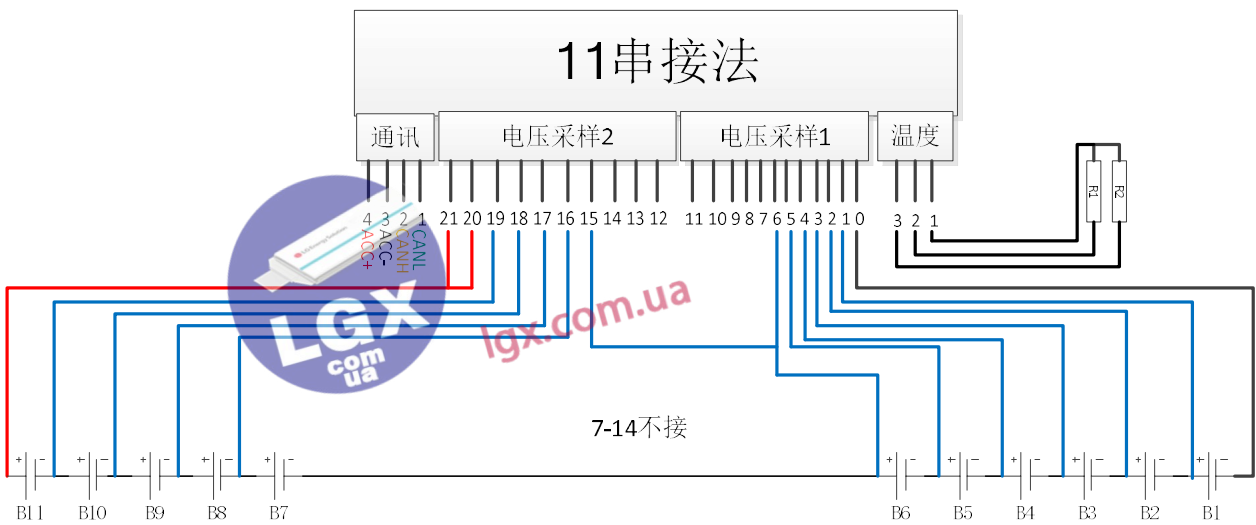

10S wiring diagram: do not use 6 to 14.

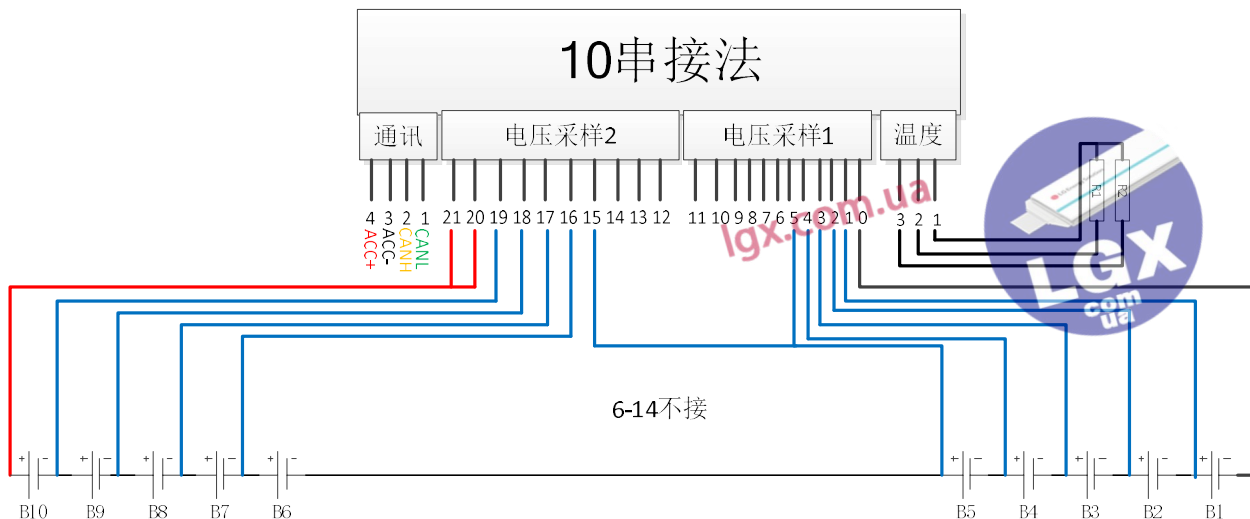

9S wiring diagram: do not use 6 to 15.

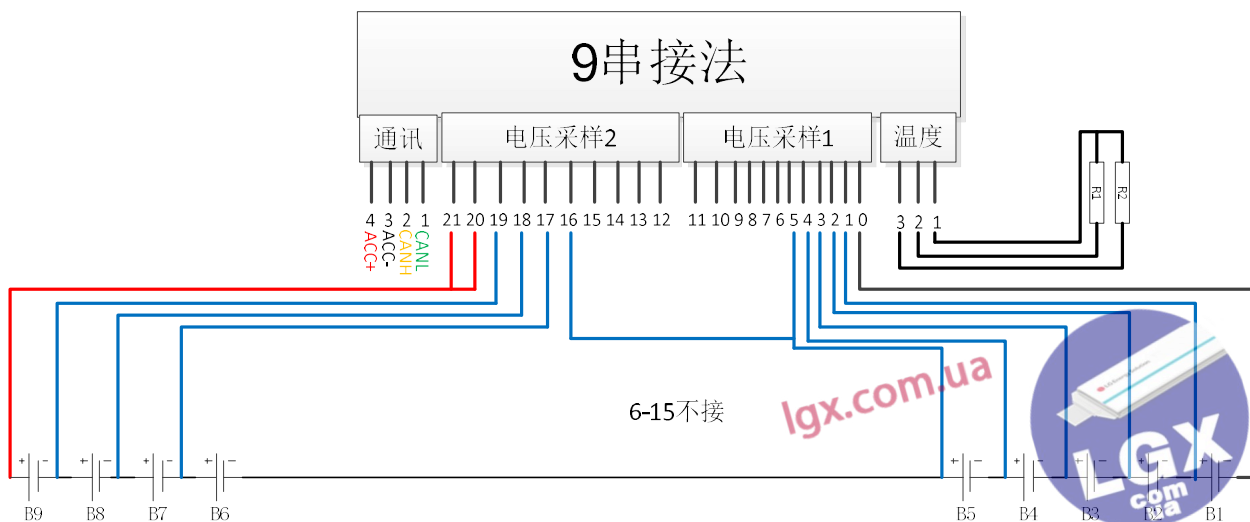

8S wiring diagram: do not use 5 to 15.

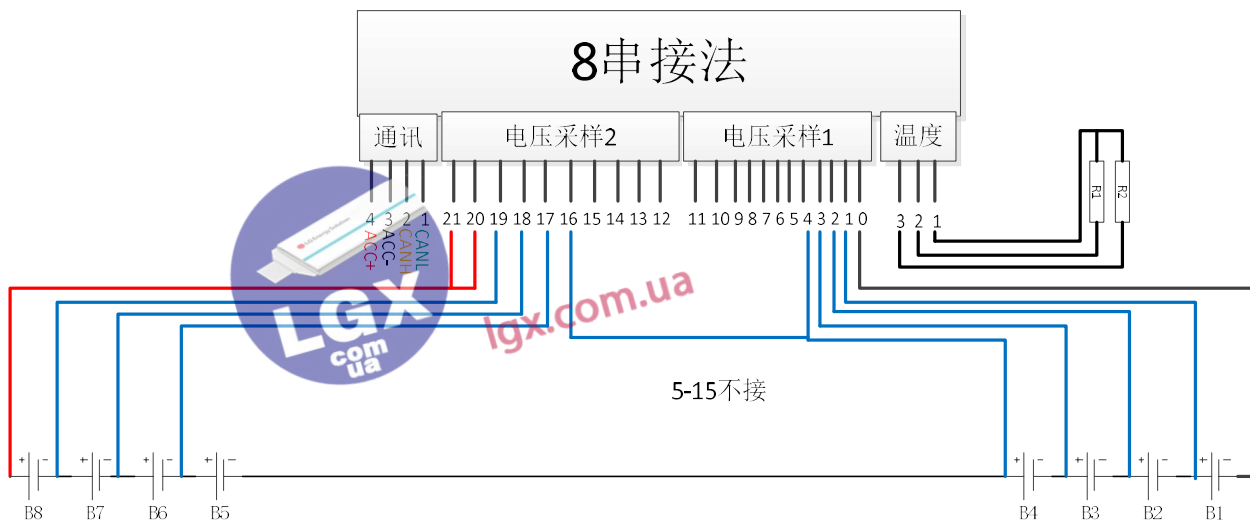

7S wiring diagram: do not use 5 to 16.

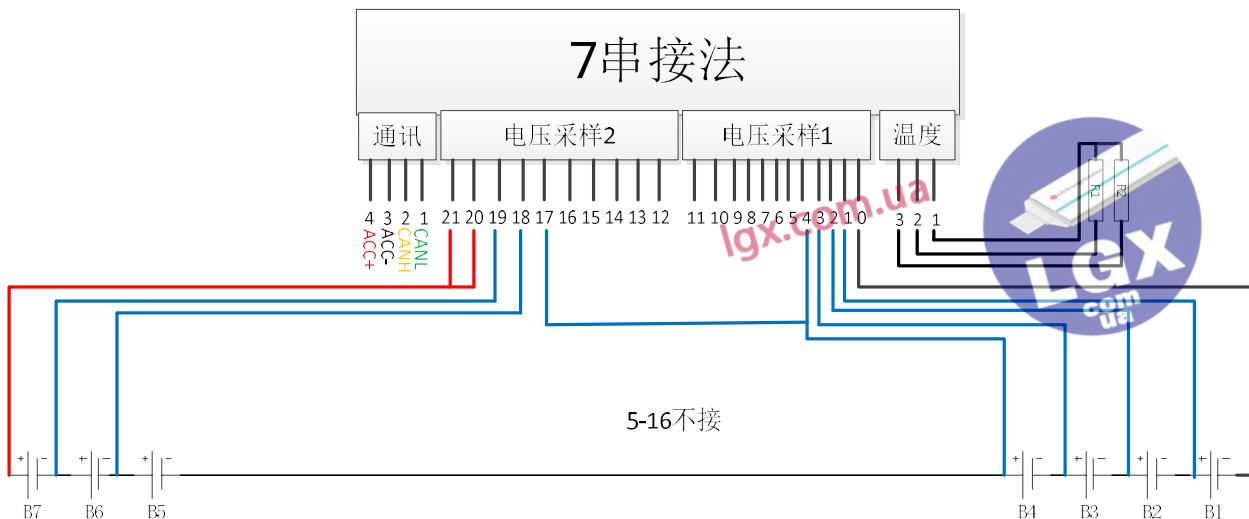

50A version Size: 140*70*17mm
 100A version Size: 140*70*17mm
 160A version Size: 180*70*17mm

