

Product Specification

Part Number: ANT-16D1-XXA1-XXX

lgx.com.ua



lgx.com.ua



lgx.com.ua

Edition: V1.0
Date:20200804

1.1 Introduction

ANT16S-XXXA-X is a smart BMS. Main function includes: cell voltage/ temperature/pack voltage/current measurement, passive balance control, CAN bus, RS485, TTL port, Bluetooth (APP supported), SOC calculation, MOS control.

1.2 System Topology

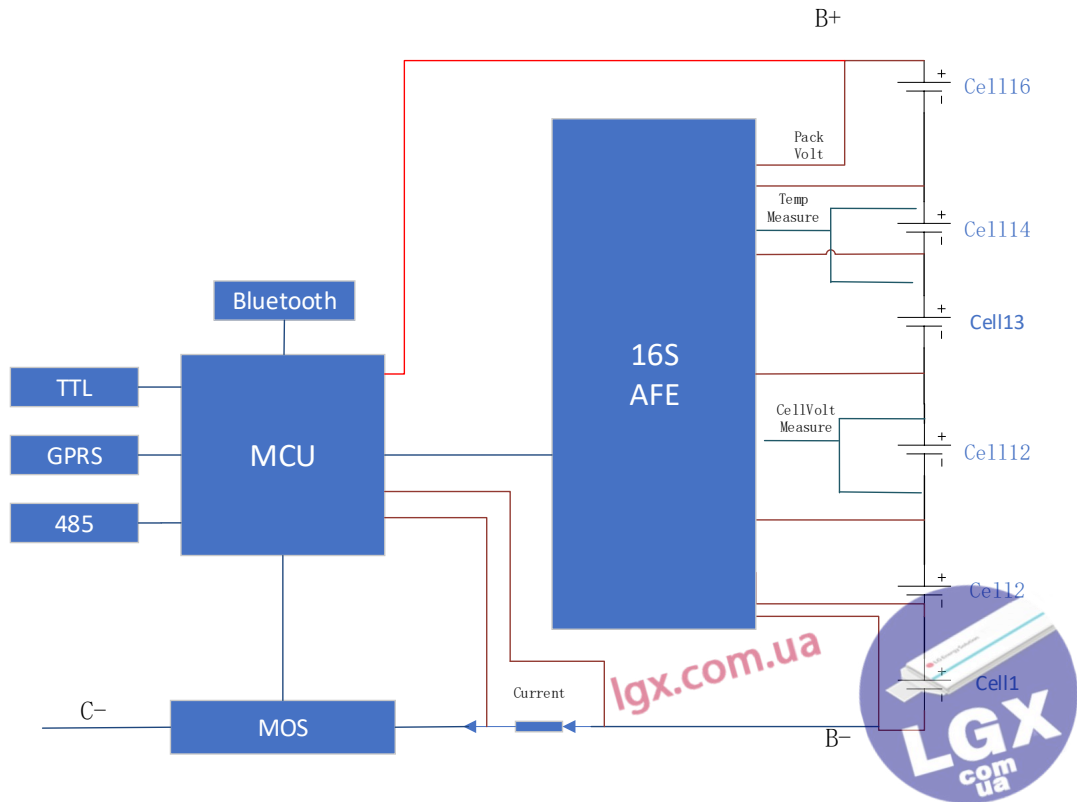

1.3 Function

1.3.1 RS485 Bus

2500V isolated。 Typical baud rate is 19200.

CAN /485/TTL can only choose one.

1.3.2 TTL Port

2500V isolated。 Typical baud rate is 19200.

Need external isolated power.**CAN /485/TTL can only choose one.**

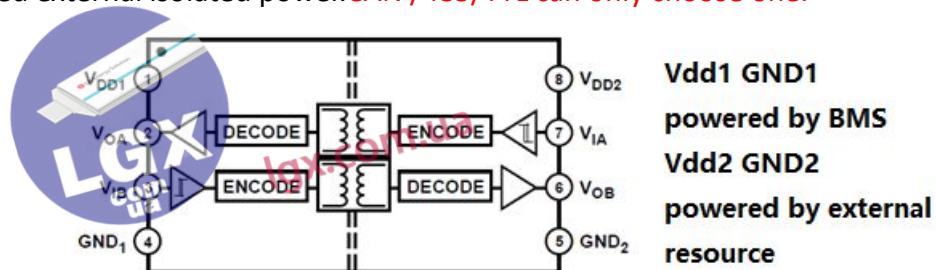

1.3.3 Cell voltage measurement

Measures Up to 16 Battery Cells in Series.

1.3.4 Temperature measurement

MOS, balance circuit, and external temperature measurement.

1.3.5 SOC

AH integral method with OCV calibration.

1.3.6 MOS Control

Drive charge & discharge MOS to protect the battery.

1.3.7 Pack voltage measurement

Pre-charge and pack voltage are get by this function.

1.3.8 Current measurement

Short-circuit, auto wake up, soc calculation.

1.3.9 Balancing

Passive cell balancing with programmable current.

100mA/ channel for maximum.



1.4 Electrical characteristics

Index	Parameter	Detail	Remark
1	Total supply voltage	20-80V DC from battery	Auto change to sleep state
2	Cell number	7-16S	
3	Working state power consumption	< 10mA (60V)	
4	Sleep state power consumption	< 5mA (60V)	Auto wake up
5	Deep sleep state power consumption	< 20uA (60V)	Manual wake up
6	Working temperature	-40 ~ 85 °C	
7	Storage temperature	-40 ~ 95 °C	
8	Working humidity	5% ~ 95%	Conformal Coating
9	Cell voltage measurement	0-5V, measurement error< 10mV Typical is 5mV	Resolution 1mV
10	Open wire detection	Supported	
11	Passive balancing	Maximum 100mA/channel	
12	Temperature measurement	-30 ~ 125 °C ,	2 channels
13	Pack voltage measurement	1 channel. 0-100V. error <0.5% FSR.	
14	Current measurement	-150A ~ 300A, error<0.5% FSR	1channel
15	SOC	< 8%	
16	CAN	1 channel, bootloader supported	Choose one in three
17	485	1 channel, bootloader supported	Choose one in three
18	TTL	1 channel, bootloader supported	Choose one in three
19	Current ability	Rated 80A, Pulse 180A (30s) The value depends highly on heat radiation.	
20	Short circuit	default 300A	
21	System log	Support	FLASH
22	Bluetooth	Support	Connect to APP
23	IP level	IP30	

24	Weight	< 400g	
25	Size	101*90*16mm	

2. Interface definition

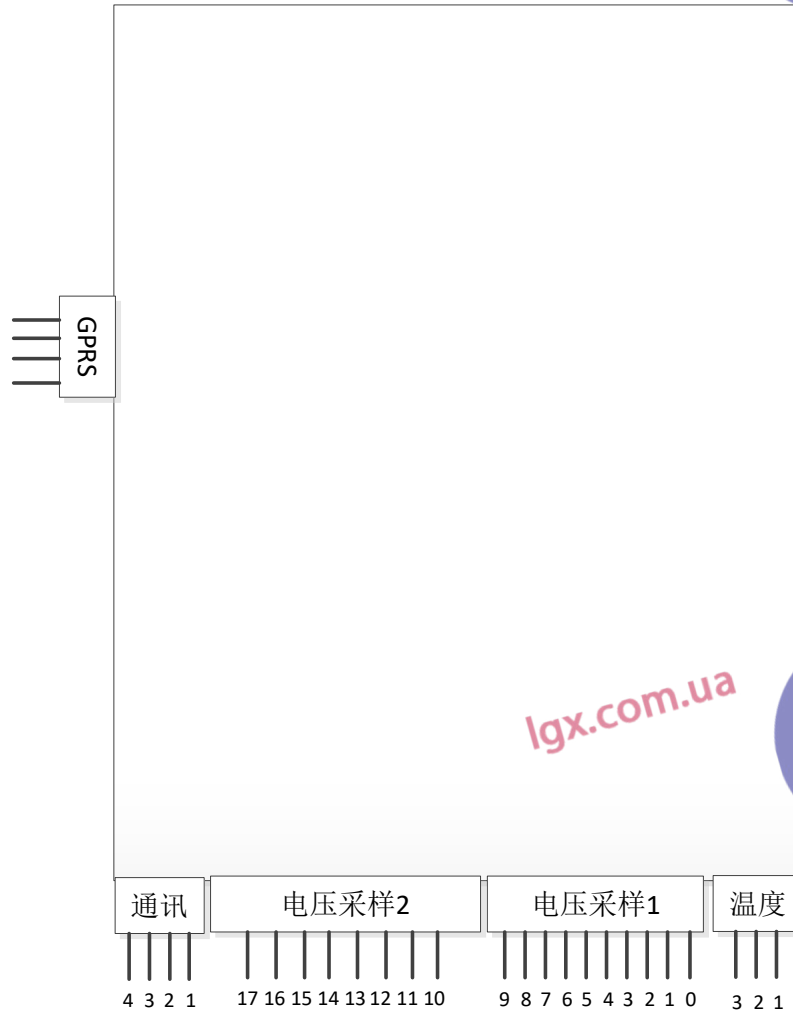

2.1 Output negative:

C-, Black wire. Charge and discharge negative share the same port.

2.2 Battery negative:

B-, blue wire. Connect to pack negative.

B- must be connected to battery first, then cell voltage interface can be plugged in.

2.3 Cell voltage port

3. 16 series cell voltage and BMS power wire.

Index	Item	Details
0	B-	Connected to pack negative
1	B1+	Connect to positive terminal of cell 1

2	B2+	Connect to positive terminal of cell 2
3	B3+	Connect to positive terminal of cell 3
4	B4+	Connect to positive terminal of cell 4
5	B5+	Connect to positive terminal of cell 5
6	B6+	Connect to positive terminal of cell 6
7	B7+	Connect to positive terminal of cell 7
8	B8+	Connect to positive terminal of cell 8
9	B9+	Connect to positive terminal of cell 9
10	B10+	Connect to positive terminal of cell 10
11	B11+	Connect to positive terminal of cell 11
12	B12+	Connect to positive terminal of cell 12
13	B13+	Connect to positive terminal of cell 13
14	B14+	Connect to positive terminal of cell 14
15	B15+	Connect to positive terminal of cell 15
16	B16+	Connect to positive terminal of cell 16
17	B+	Connect to pack positive

For application less than 16s, please refer to the wiring guidance!!!

3.1 Temperature port

Index	Item	Details	Index	Item	Details
1	GND	NTC common ground	3	T2	NTC2 positive
2	T1	NTC1 positive			

3.2 Communication port

Index	Item	Details	Index	Item	Details
1	CANL	CAN Low/485B	3	ACC-	Activation negative
2	CANH	CANHigh/485A	4	ACC+	Activation positive

Remark: A Voltage source range from 3-12V can activate BMS via ACC + and ACC-.

By the way, a charger can also activate BMS.

3.3 GPRS port

Index	Item	Details	Index	Item	Details
1	V	Battery total positive	4	RX	BMS signal reception
2	TX	BMS signal transmission	5	G	GND

4. Wiring

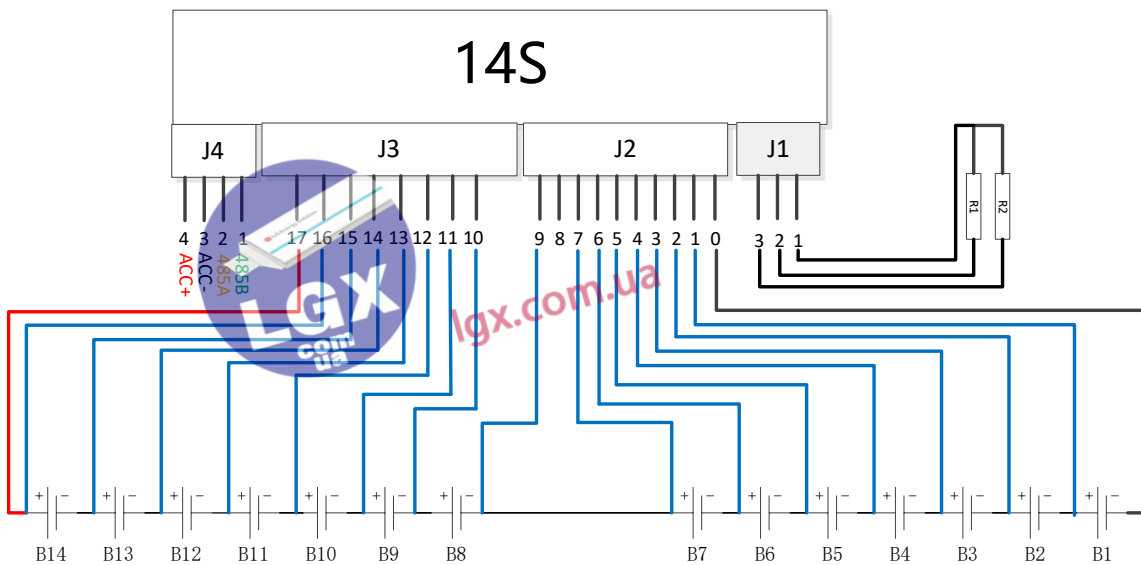
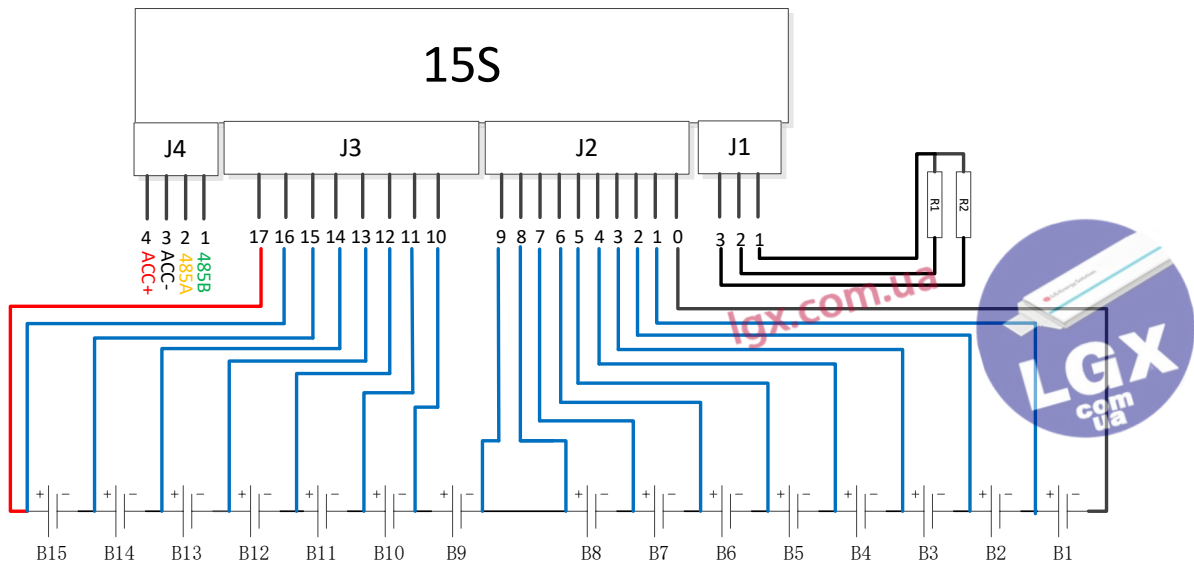
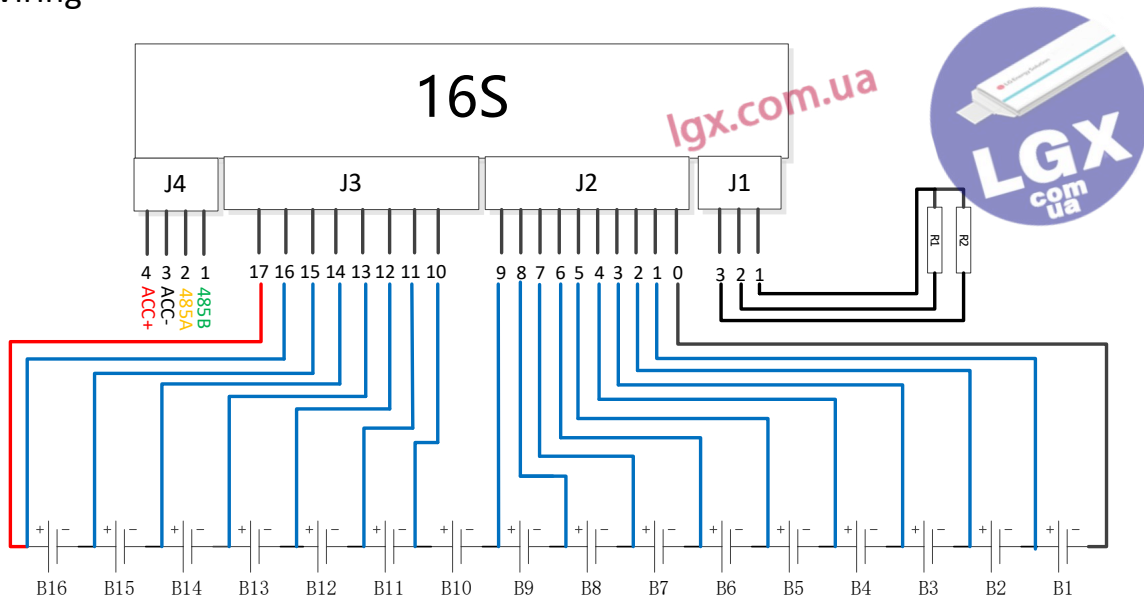

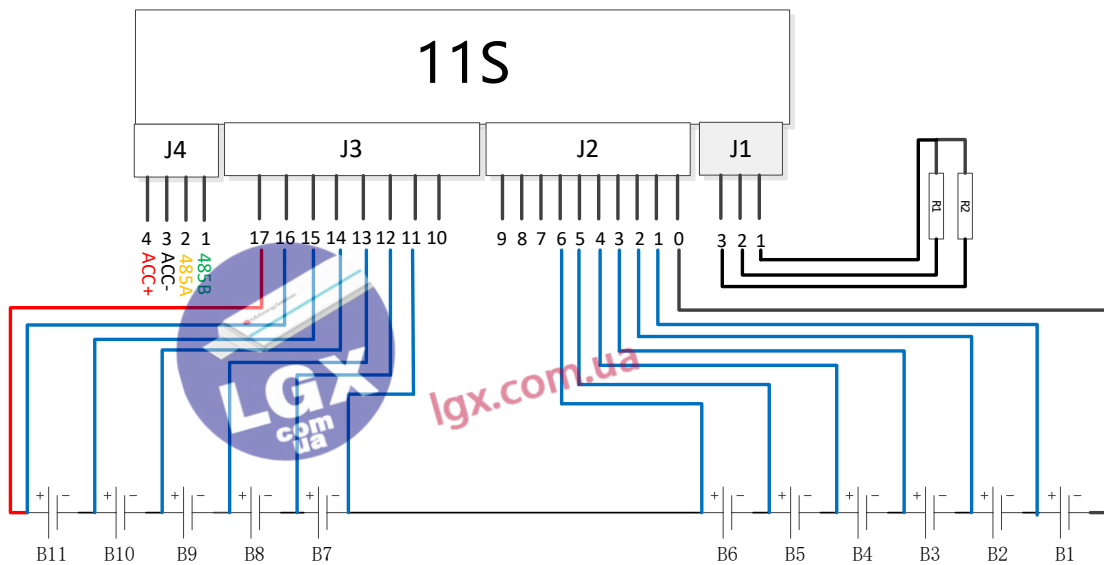
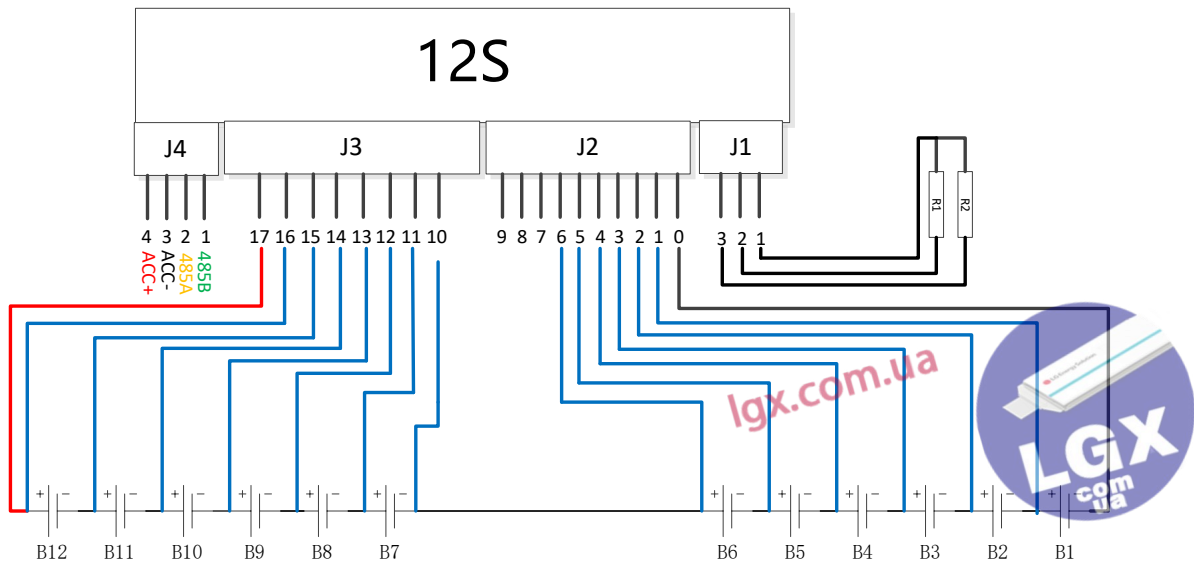
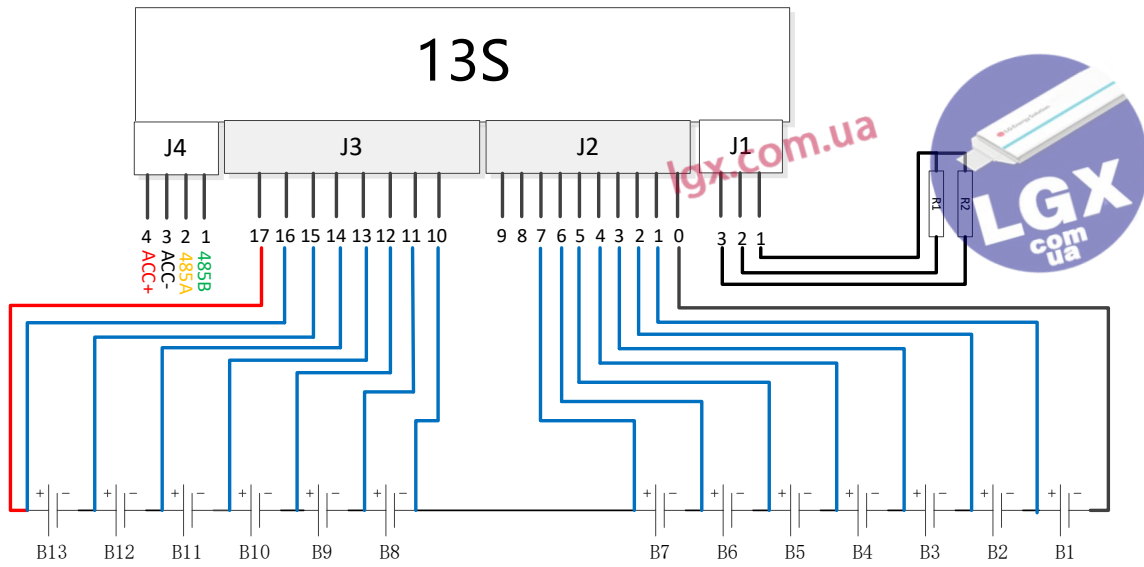

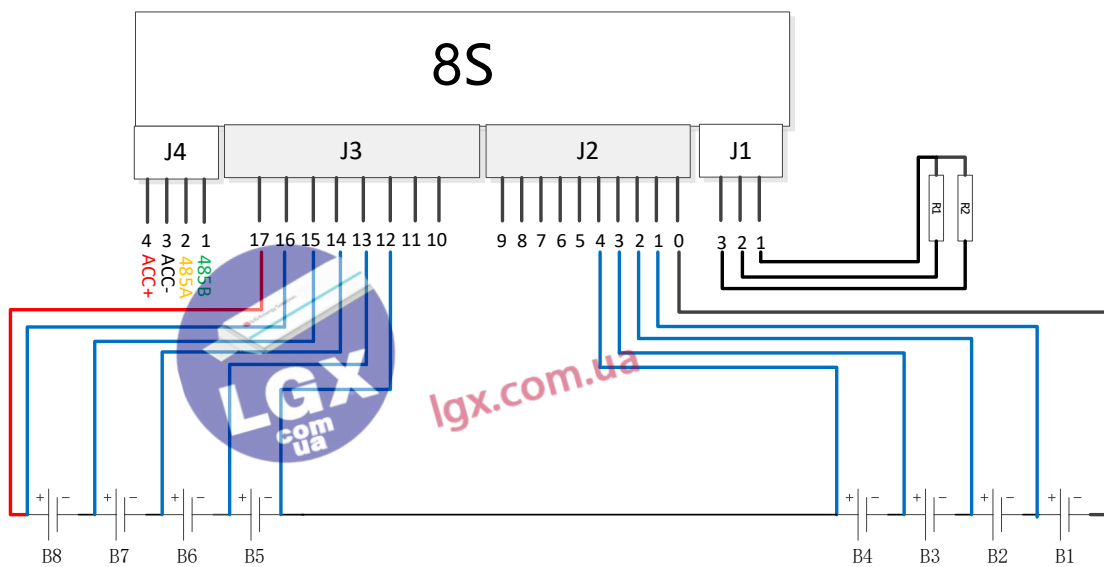
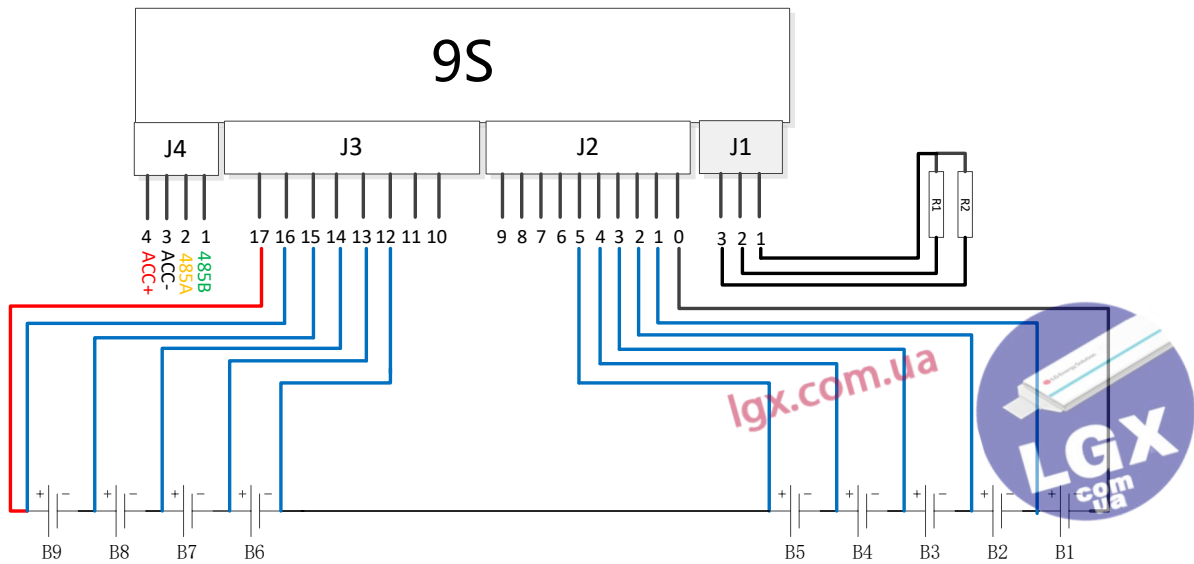
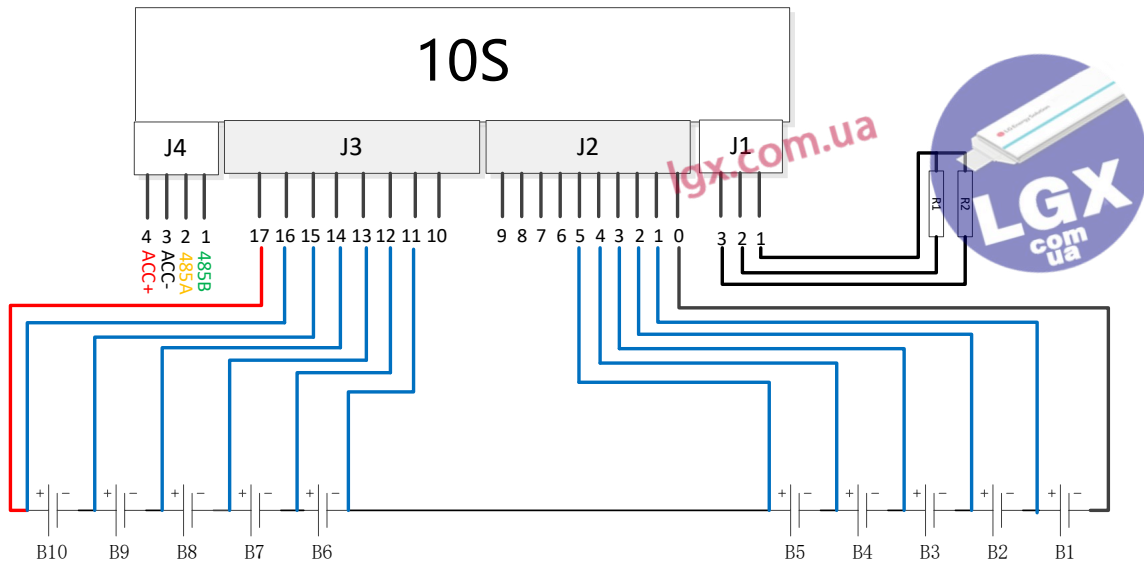

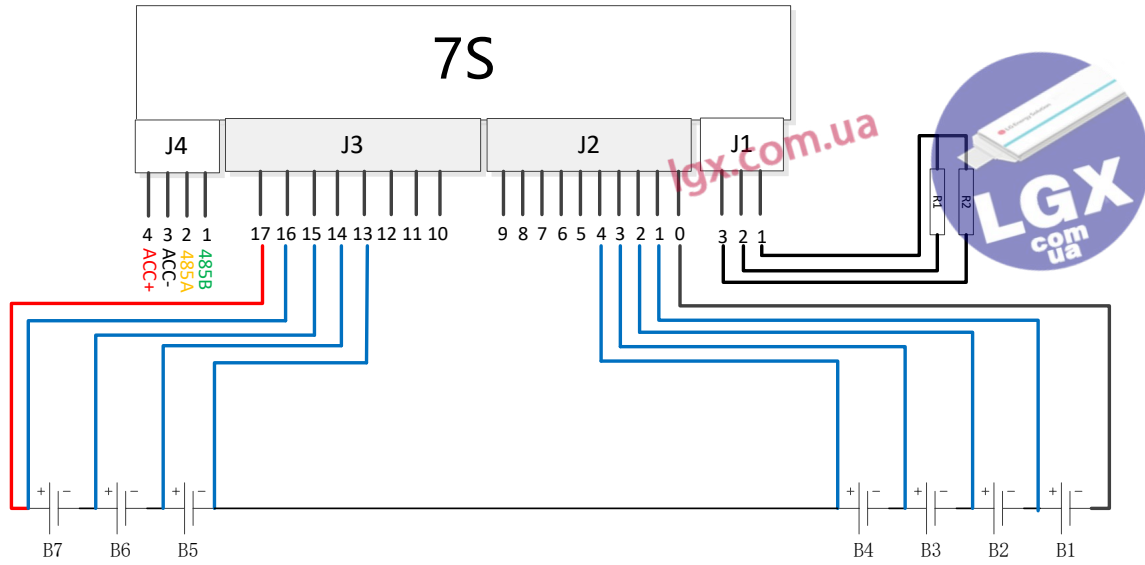

5. PC software



lgx.com.ua

6. APP



BMS Control



BMS Parameter setting



BMS State



lgx.com.ua

7. Structure

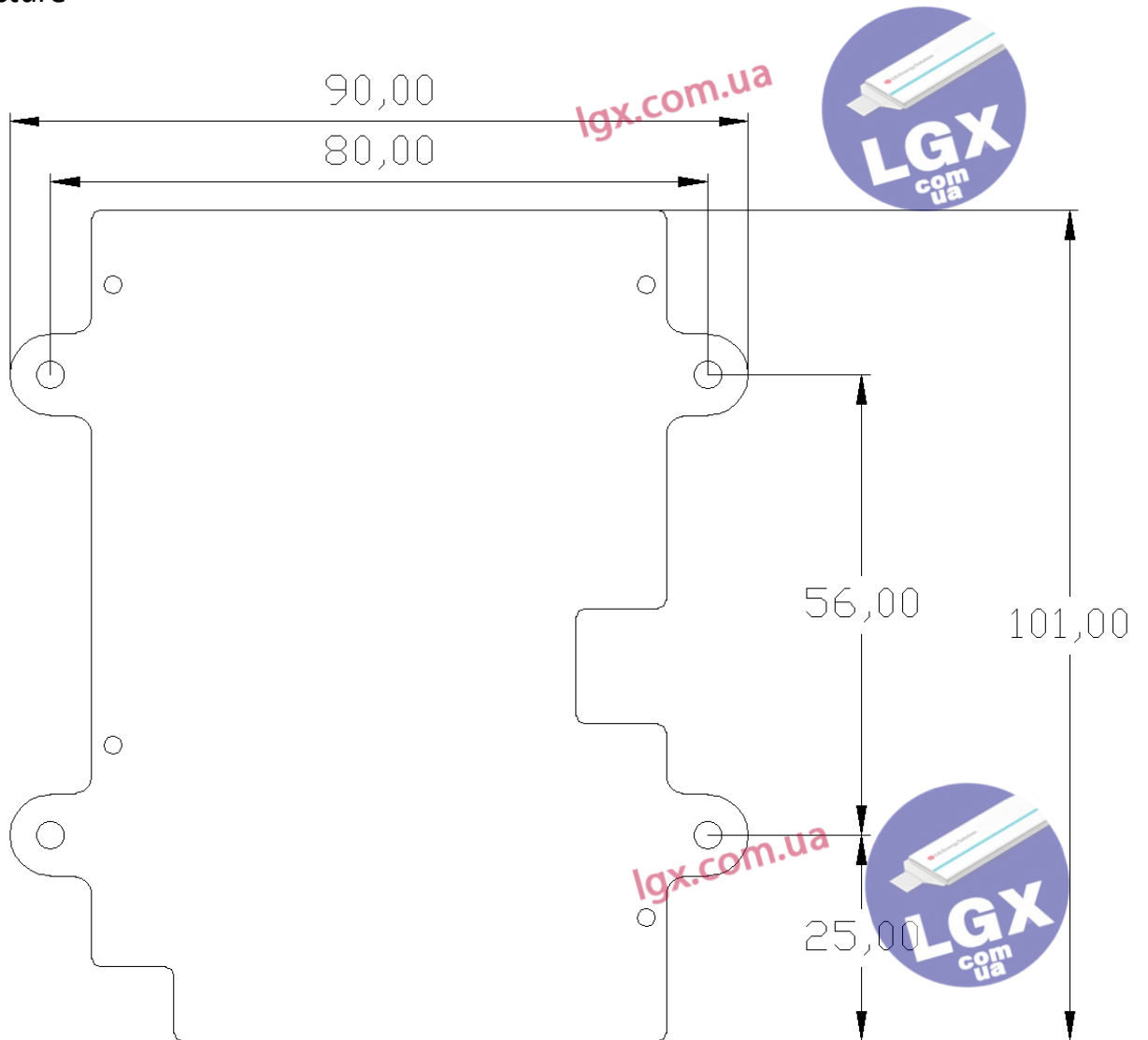

lgx.com.ua