

# Product Specification

Part Number: ANT20S-500A-X



lgx.com.ua

Edition: V1.4  
Date: 20200303

## 1.1 Introduction

ANT20S-500A-X is a smart BMS. Main function includes: cell voltage/ temperature/pack voltage/current measurement, passive balance control, CAN bus, RS485, TTL port, Bluetooth (APP supported), SOC calculation, MOS control.

## 1.2 System Topology

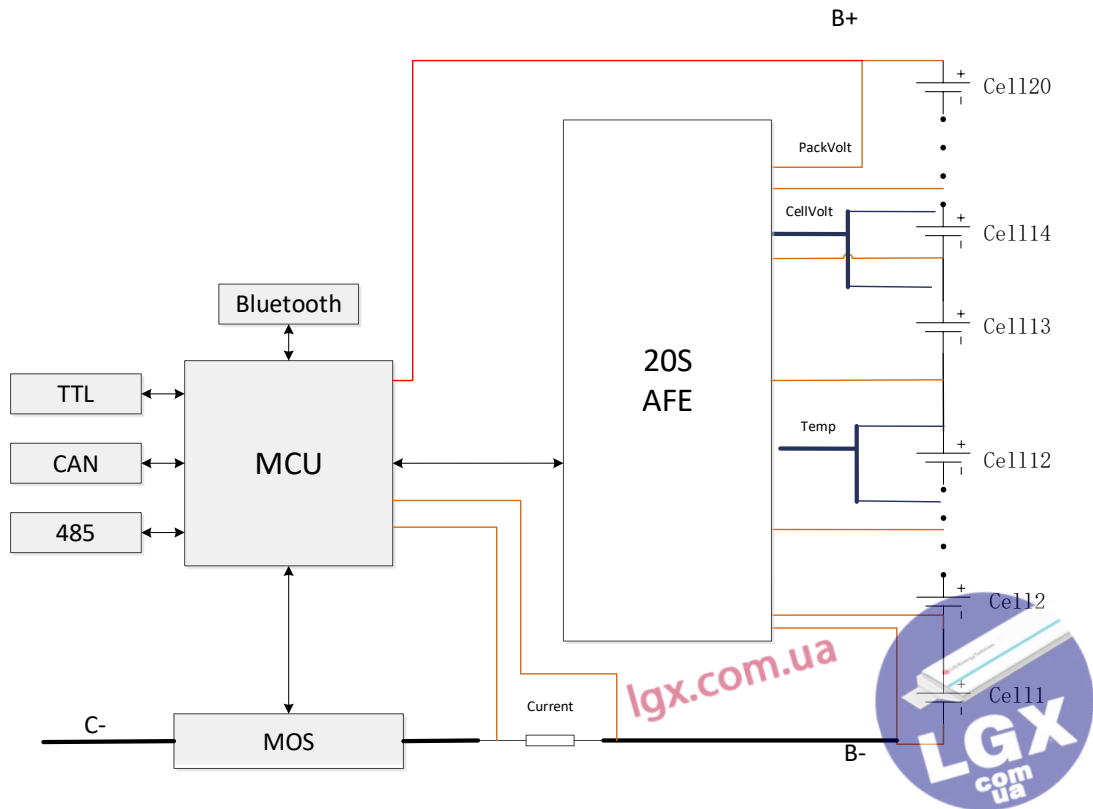

## 1.3 Function

### 1.3.1 CAN Bus

J N1939 protocol, CAN2.0A/B supported. 2500V isolated.

**CAN /485/TTL can only choose one.**

### 1.3.2 RS485 Bus

2500V isolated。 Typical baud rate is 19200.

**CAN /485/TTL can only choose one.**

### 1.3.3 TTL Port

2500V isolated。 Typical baud rate is 19200.

Need external isolated power.**CAN /485/TTL can only choose one.**

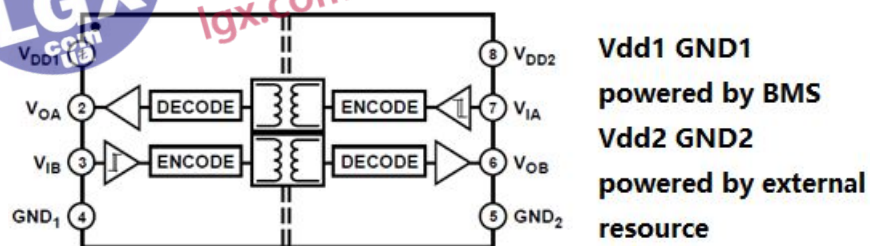

- 1.3.4 Cell voltage measurement  
Measures Up to 16 Battery Cells in Series.
- 1.3.5 Temperature measurement  
MOS, balance circuit, and external temperature measurement.
- 1.3.6 SOC  
AH integral method with OCV calibration.
- 1.3.7 MOS Control  
Drive charge & discharge MOS to protect the battery.
- 1.3.8 Pack voltage measurement  
Pre-charge and pack voltage are get by this function.
- 1.3.9 Current measurement  
Short-circuit, auto wake up, soc calculation.
- 1.3.10 Balancing  
Passive cell balancing with programmable current.  
100mA/ channel for maximum.



#### 1.4 Electrical characteristics

Index	Parameter	Detail	Remark
1	Total supply voltage	20-80V DC from battery	Auto change to sleep state
2	Cell number	8-20S	
3	Working state power consumption	< 10mA (72V)	
4	Sleep state power consumption	< 5mA (72V)	Auto wake up
5	Deep sleep state power consumption	< 20uA (72V)	Manual wake up
6	Working temperature	-40 ~ 85 °C	
7	Storage temperature	-40 ~ 95 °C	
8	Working humidity	5% ~ 95%	Conformal Coating
9	Cell voltage measurement	0-5V, measurement error< 10mV Typical is 5mV	Resolution 1mV
10	Open wire detection	Supported	
11	Passive balancing	Maximum 100mA/channel	
12	Temperature measurement	-30 ~ 125 °C ,	2 channels
13	Pack voltage measurement	1 channel. 0-100V. error <0.5% FSR.	
14	Current measurement	-150A ~ 300A, error<0.5% FSR	1channel
15	SOC	< 8%	
16	CAN	1 channel, bootloader supported	Choose one in three
17	485	1 channel, bootloader supported	Choose one in three
18	TTL	1 channel, bootloader supported	Choose one in three
19	Current ability	Rated 180A, Pulse 500A (30s) The value depends highly on heat radiation.	
20	Short circuit	closed	

21	System log	Support	FLASH
22	Bluetooth	Support	Connect to APP
23	IP level	IP30	
24	Weight	< 400g	
25	Size	195*70*16mm	

## 2. Interface definition

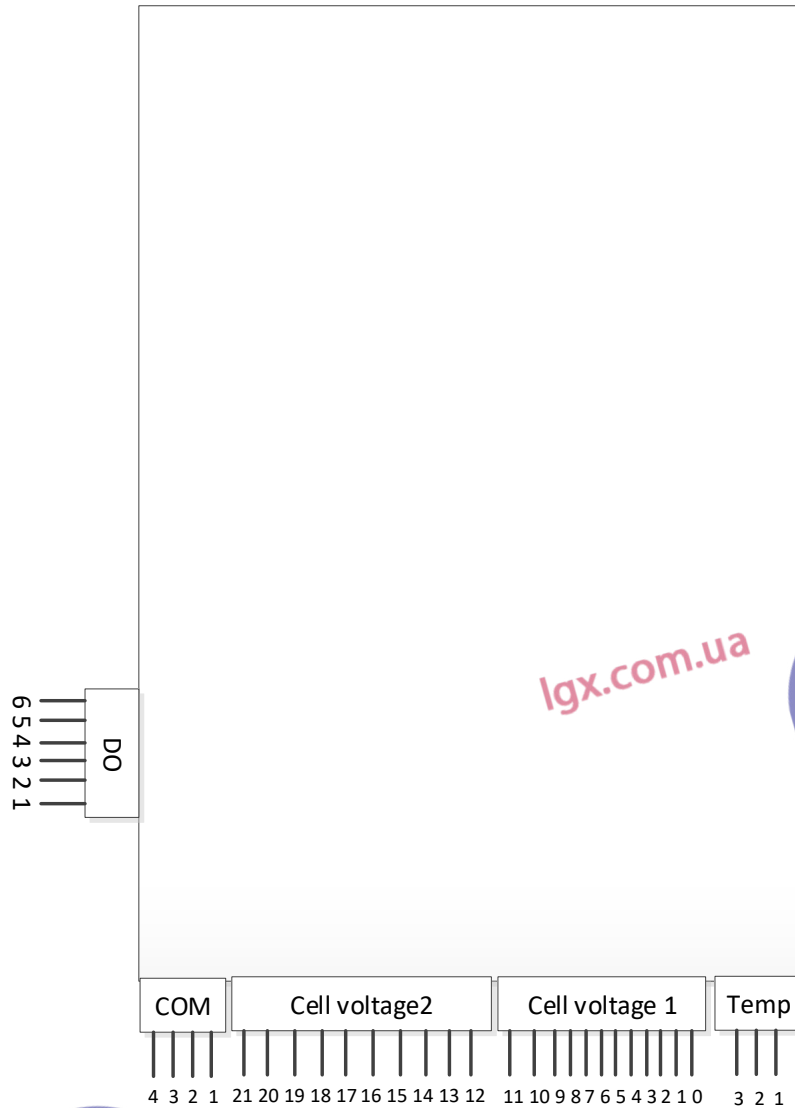

### 2.1 Output negative:

**C-**, **Black wire**. Charge and discharge negative share the same port.

### 2.2 Battery negative:

**B-**, **blue wire**. Connect to pack negative.

**B- must be connected to battery first, then cell voltage interface can be plugged in.**

### 2.3 Cell voltage port

20 series cell voltage and BMS power wire.

Index	Item	Details
0	B-	Connected to pack negative
1	B1+	Connect to positive terminal of cell 1
2	B2+	Connect to positive terminal of cell 2
3	B3+	Connect to positive terminal of cell 3
4	B4+	Connect to positive terminal of cell 4
5	B5+	Connect to positive terminal of cell 5
6	B6+	Connect to positive terminal of cell 6
7	B7+	Connect to positive terminal of cell 7
8	B8+	Connect to positive terminal of cell 8
9	B9+	Connect to positive terminal of cell 9
10	B10+	Connect to positive terminal of cell 10
11	B11+	Connect to positive terminal of cell 11
12	B12+	Connect to positive terminal of cell 12
13	B13+	Connect to positive terminal of cell 13
14	B14+	Connect to positive terminal of cell 14
15	B15+	Connect to positive terminal of cell 15
16	B16+	Connect to positive terminal of cell 16
17	B17+	Connect to positive terminal of cell 17
18	B18+	Connect to positive terminal of cell 18
19	B19+	Connect to positive terminal of cell 19
20	B20+	Connect to positive terminal of cell 20
21	B+	Connect to pack positive

**For application less than 16s, please refer to the wiring guidance!!!**

## 2.4 Temperature port

Index	Item	Details	Index	Item	Details
1	GND	NTC common ground	3	T2	NTC2 positive
2	T1	NTC1 positive			

## 2.5 Communication Port

Index	Item	Details	Index	Item	Details
1	CANL	CAN Low/485B	3	ACC-	Activation negative
2	CANH	CANHigh/485A	4	ACC+	Activation positive

Remark: A Voltage source range from 3-12V can activate BMS via ACC + and ACC-.

By the way, a charger can also activate BMS.

## 2.6 DO

Index	Item	Details	Index	Item	Details
1	DO1+	DO1 output	4	DO2-	DO2 output
2	DO1-		5	DO3+	DO3 output
3	DO2+	DO2 output	6	DO3-	



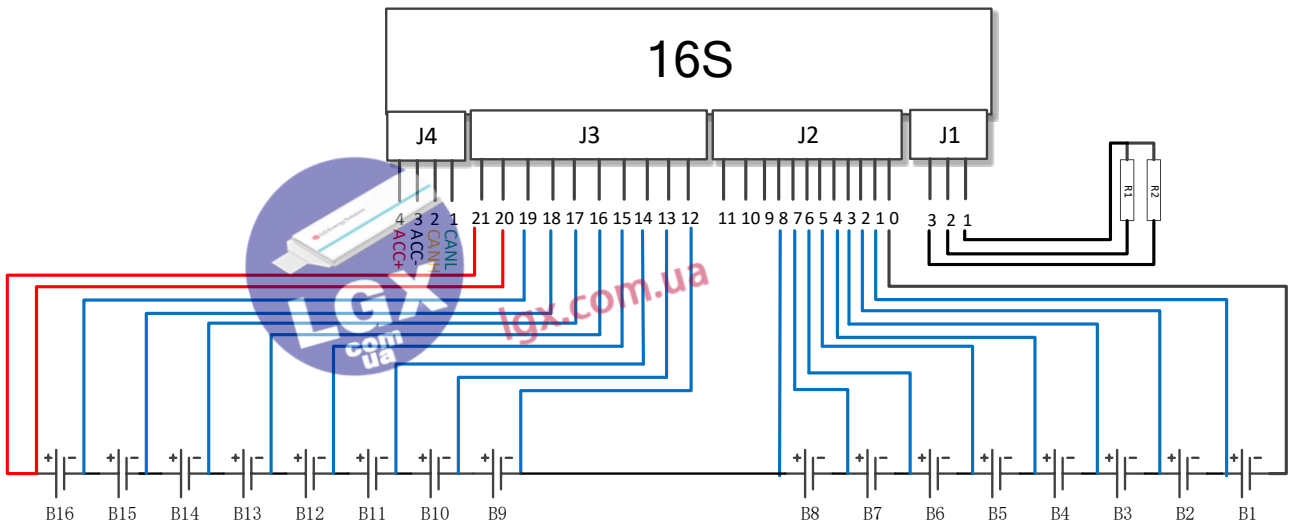
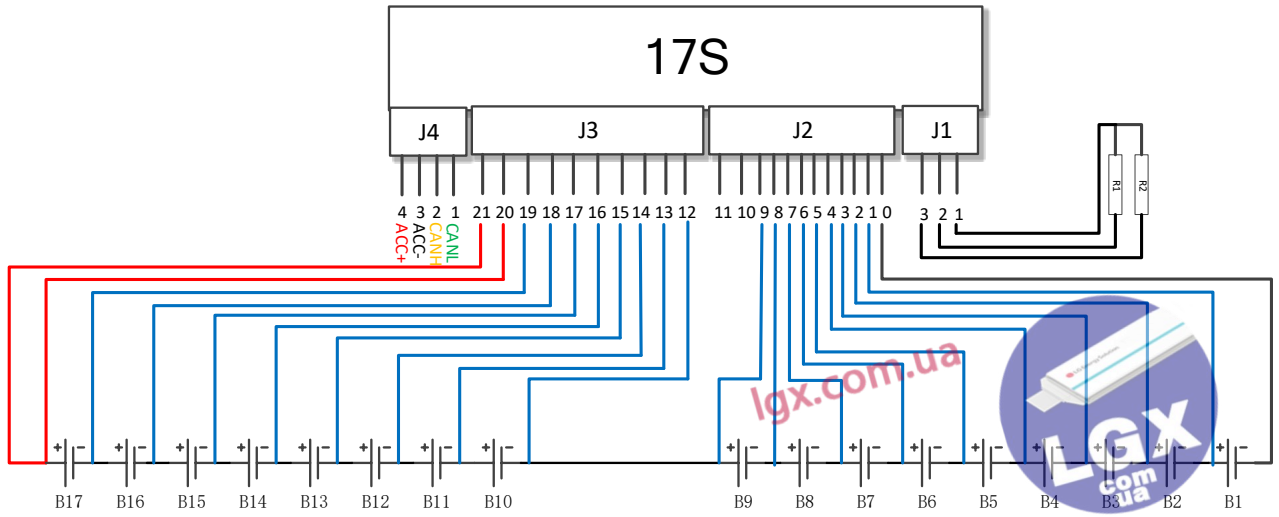
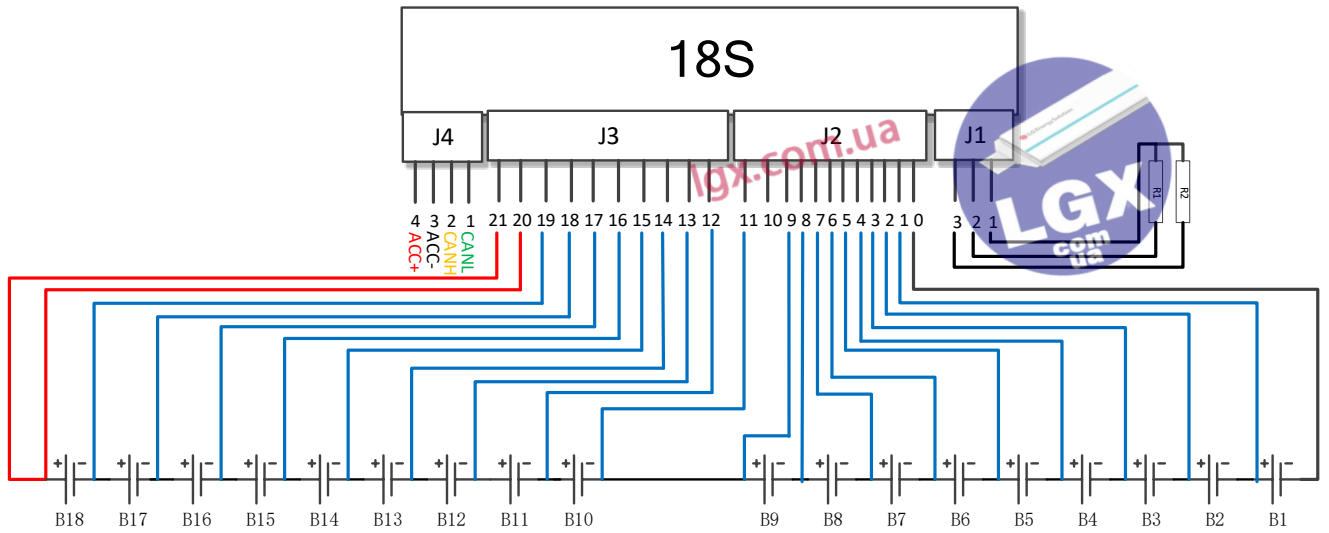

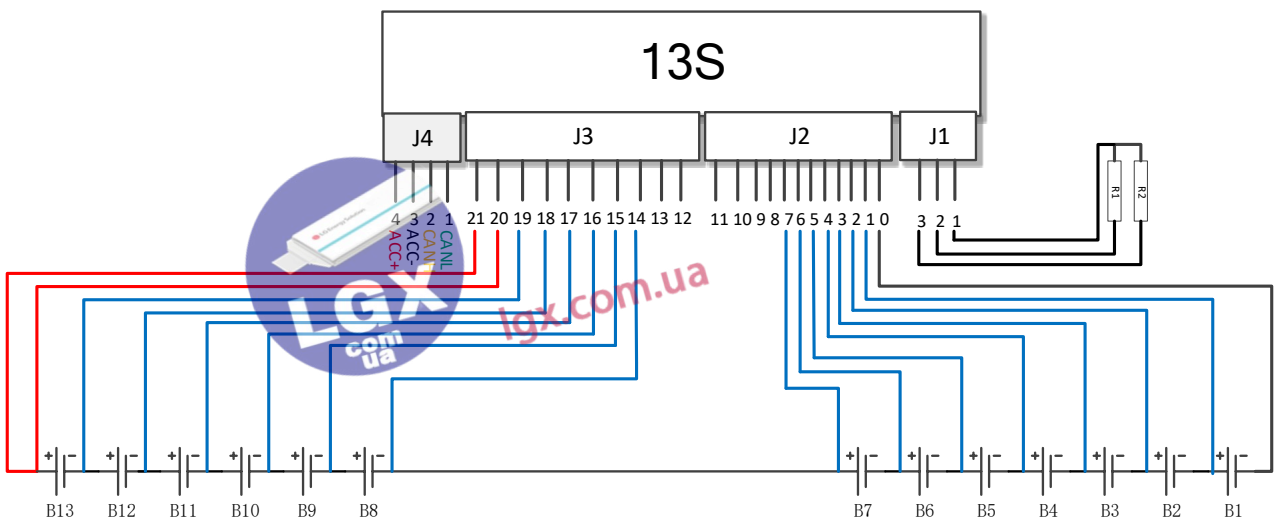
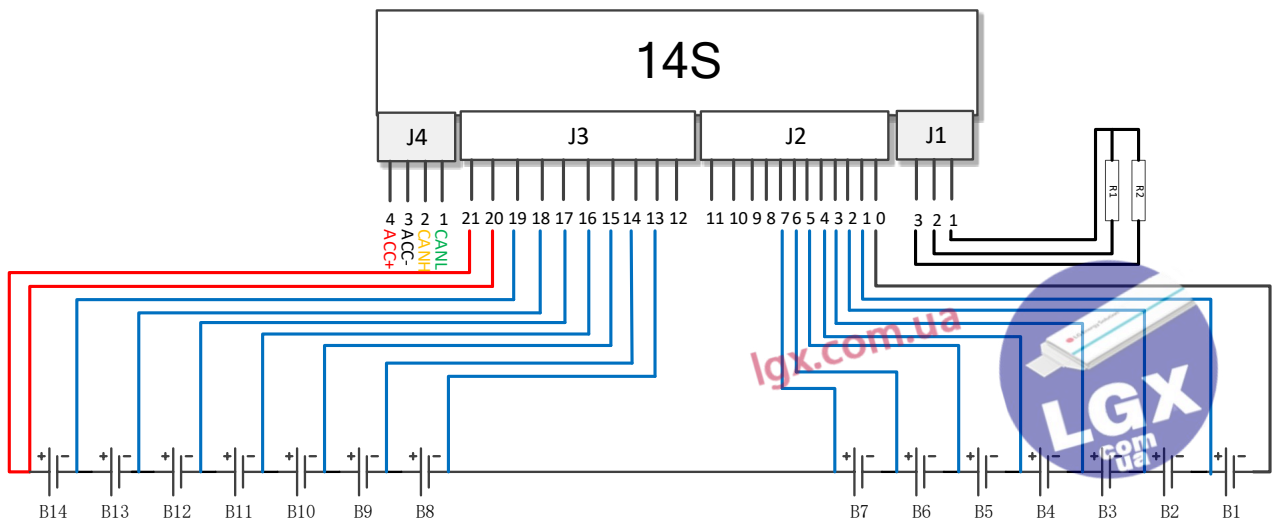
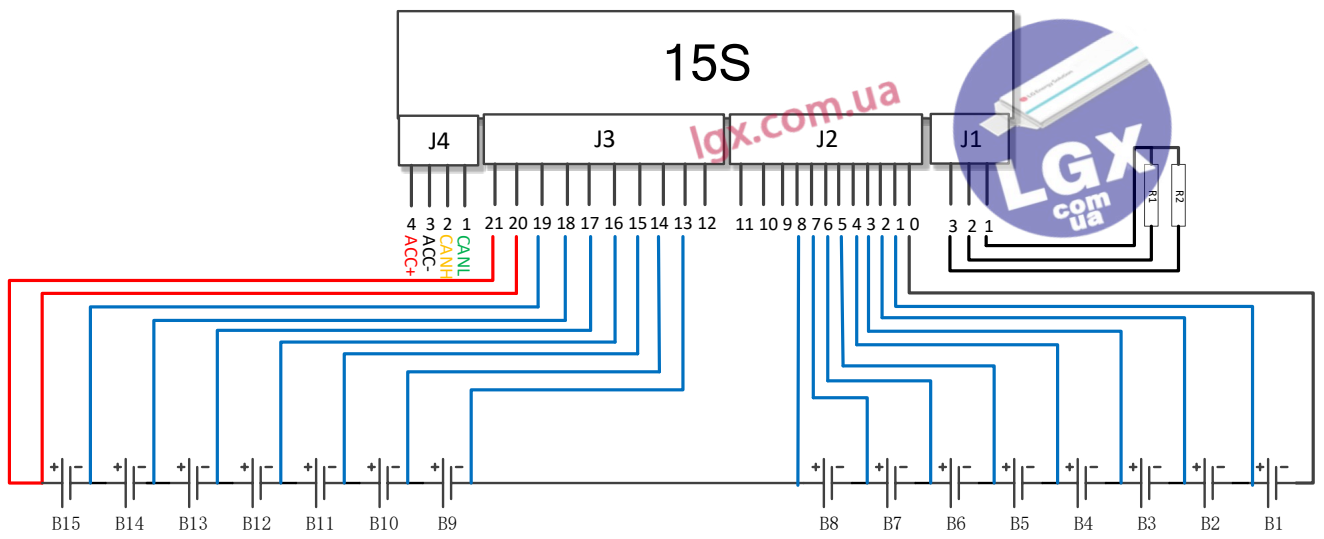



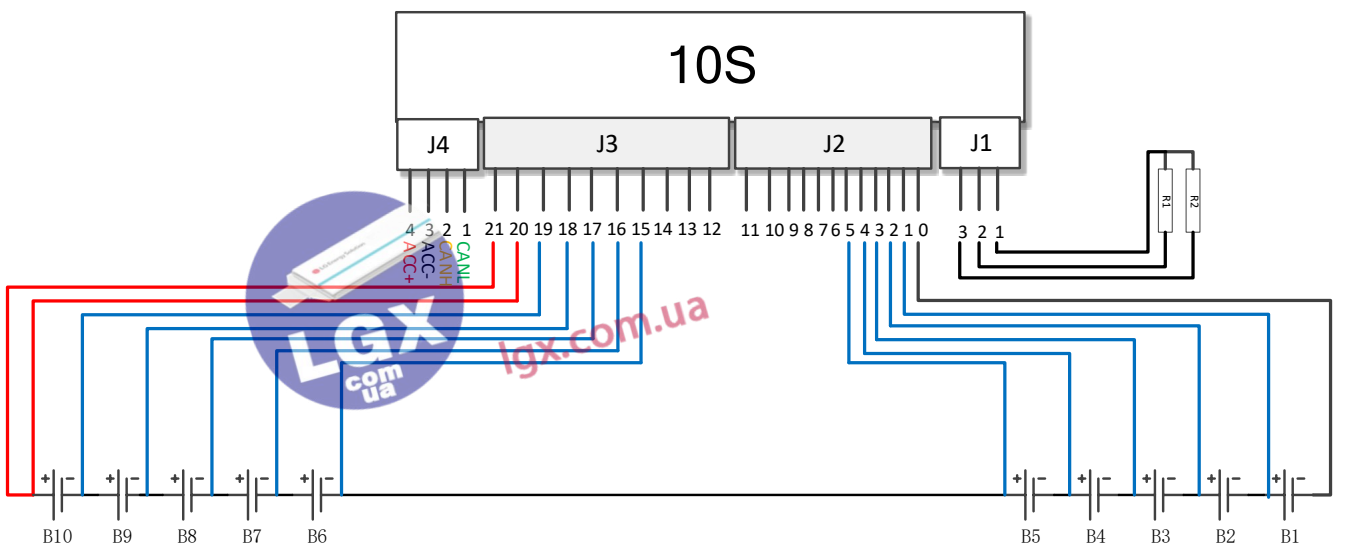
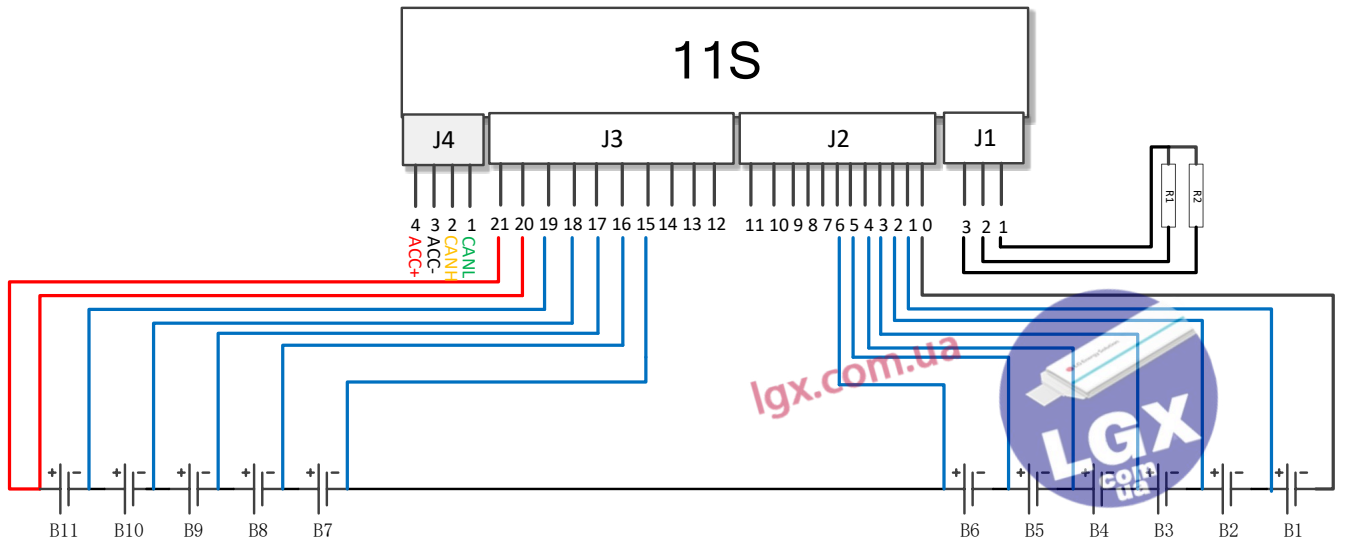
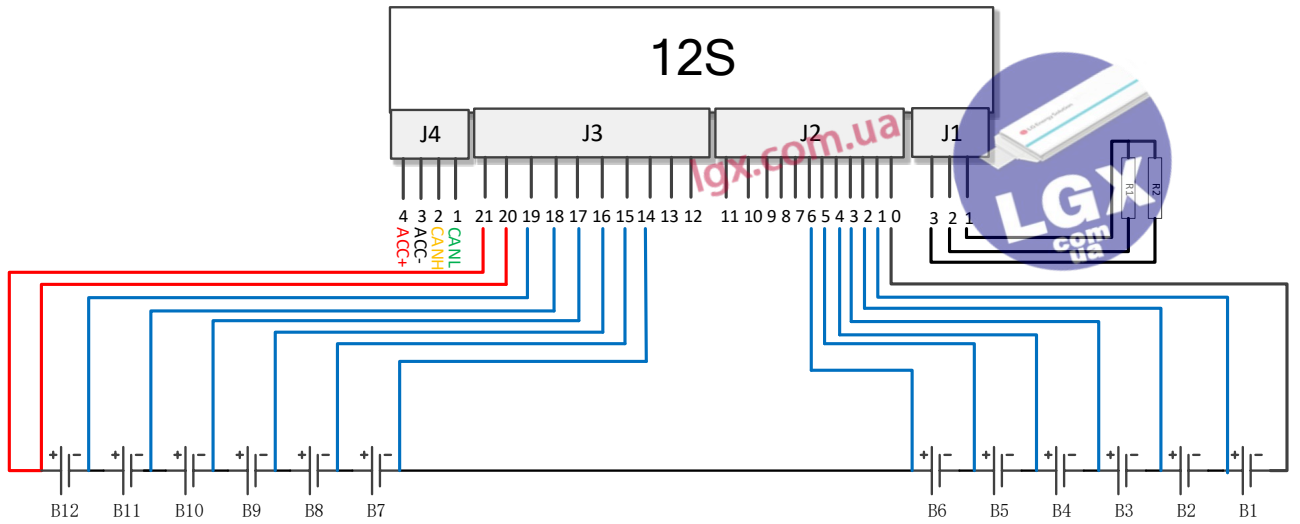

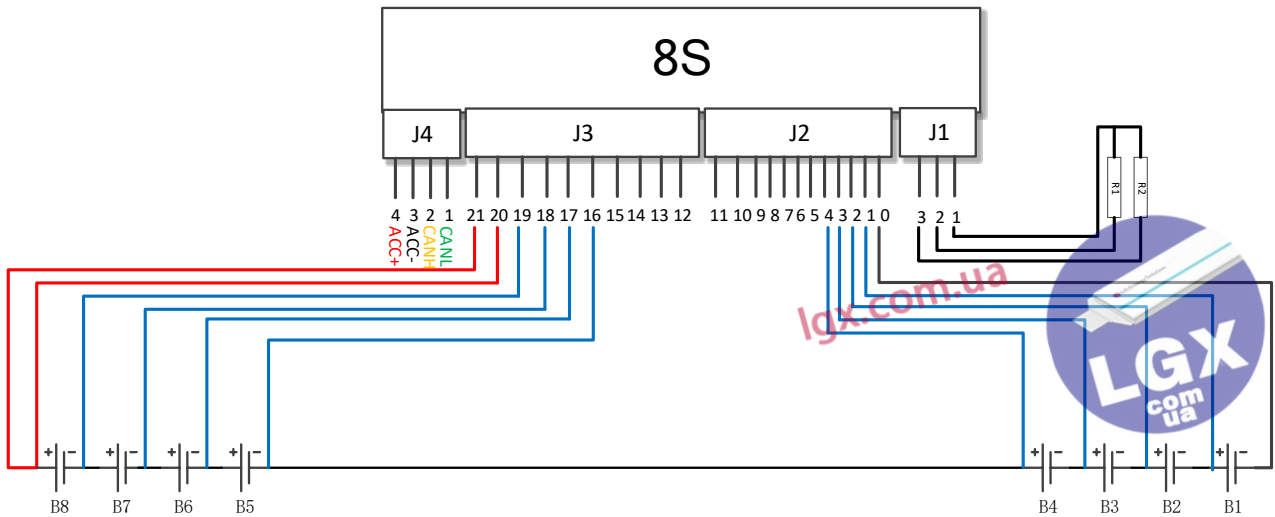
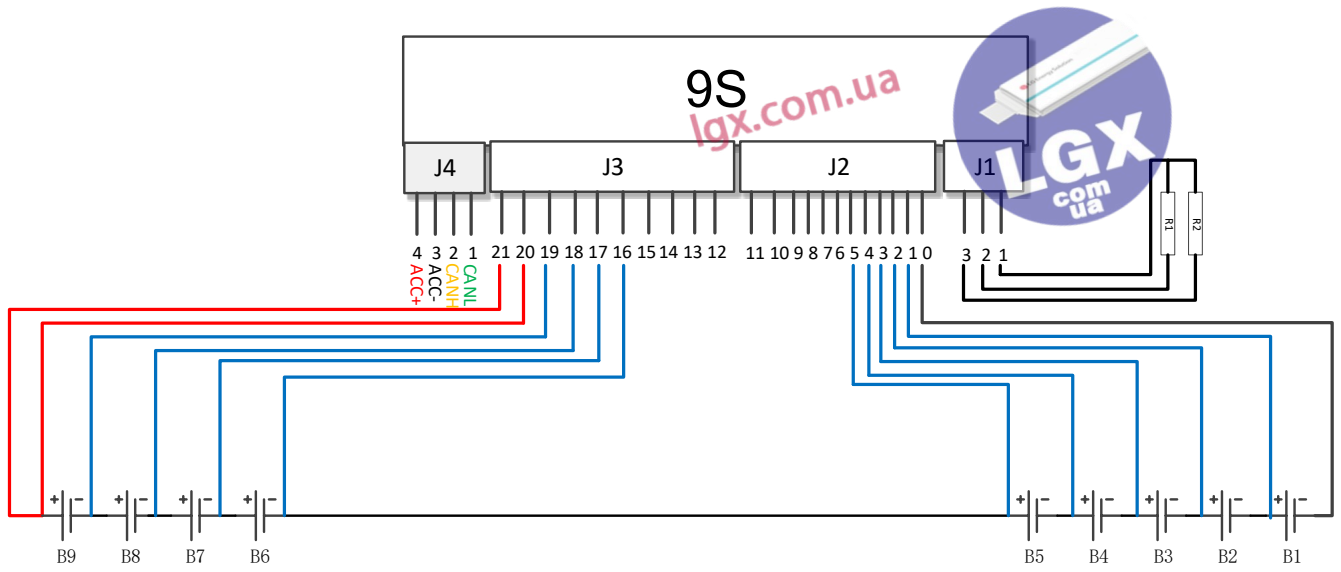

lgx.com.ua

## 4. PC software



The screenshot shows the BMS\_V1.5 software interface. It includes sections for connection settings (COM3, 19200 baud), MOS status (charging and discharging MOS are on), battery status (total voltage 64.6V, SOC 89%, remaining capacity 88.299AH), and a system log table. The log table contains 29 entries, each with a status like '<充电>(0)开启' or '<放电>(0)开启'.

## 5. APP



The screenshot shows the BMS APP control screen. It features a '连接...' button, a '设置可见' button, and a '连接设备' button. Below these are input fields for '验证密码' and '修改密码'. At the bottom, there are buttons for '打开充电', '打开放电', '关闭充电', '关闭放电', '重启系统', '出厂设置', '自动均衡', and '铁锂参数'.

BMS 控制



The screenshot shows the BMS APP system parameter settings screen. It has a table with columns for '项目' (Item), '机器参数' (Machine Parameter), and '设定参数' (Set Parameter). The table lists various protection and monitoring parameters like '单体过压警告', '总压过压保护', '充电过流保护', etc., with their current values and '设置' (Set) buttons.

BMS 系统参数设置



The screenshot shows the BMS APP real-time status screen. It displays a list of battery cell voltages from [01] to [15], all showing 4.035 V. It also shows various system parameters like 'RV:16043', '运行时间:53天1时31分17秒', and '充电MOS: 开启'.

BMS 实时状态

## 6. Part Number definition

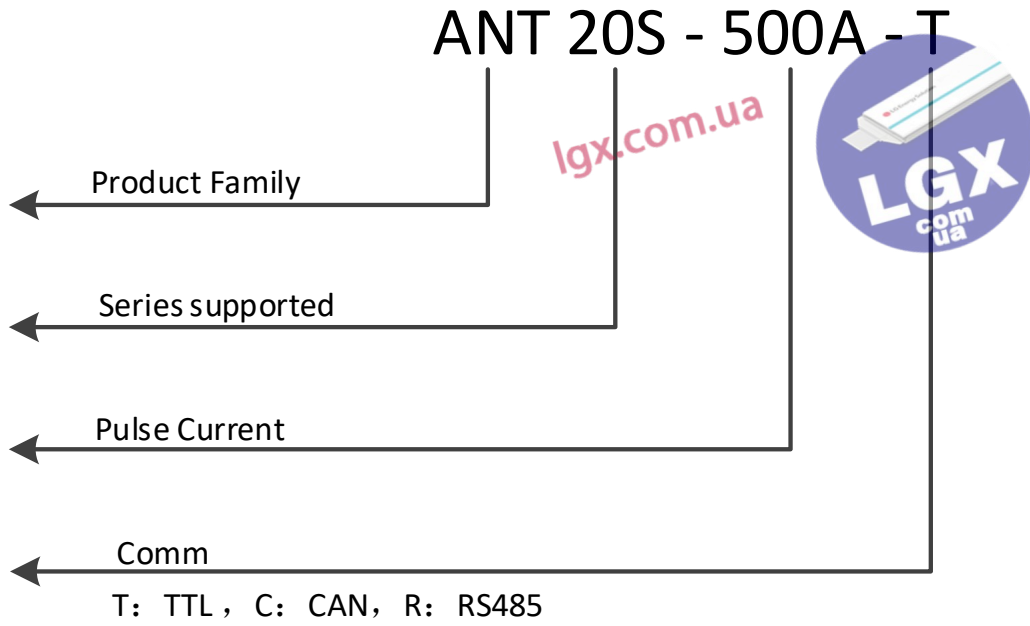

Example: ANT20S-500A-C means 20S pulse current 500A, CAN port  
ANT20S-500A-T means 20S pulse current 500A, TTL port

## 7. Structure

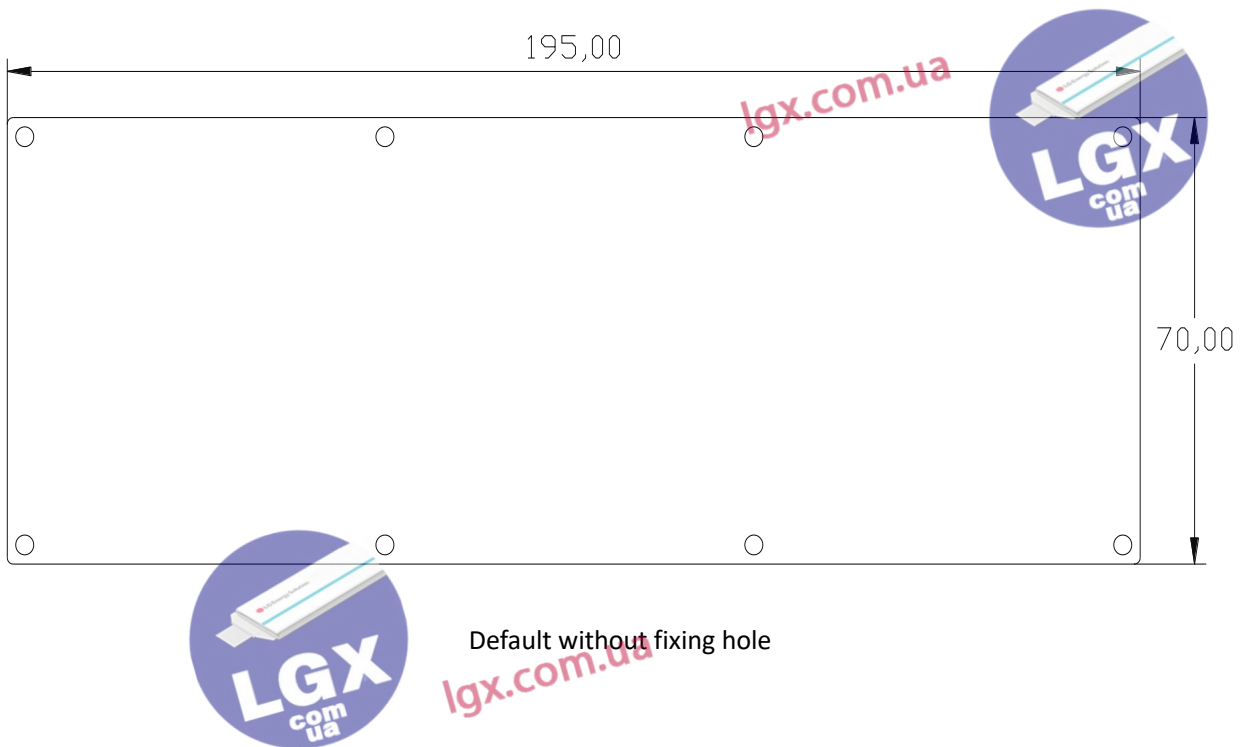

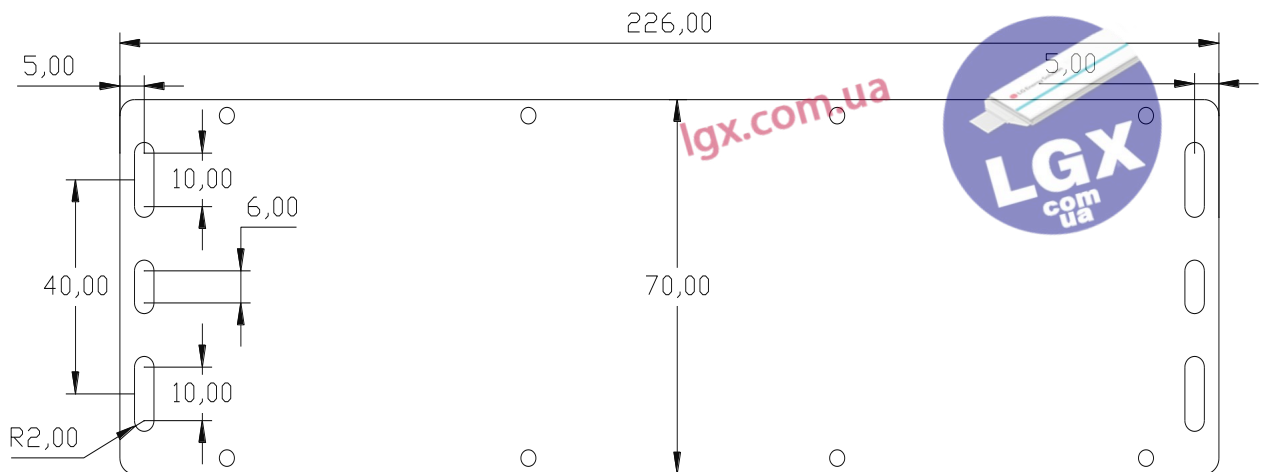

With fixing hole for option

[lgx.com.ua](http://lgx.com.ua)



[lgx.com.ua](http://lgx.com.ua)