

Product Specification

Part Number: ANT16S-XXXXA-X



lgx.com.ua



lgx.com.ua



lgx.com.ua

Edition: V1.4
Date: 20200303

1.1 Introduction

ANT16S-XXXA-X is a smart BMS. Main function includes: cell voltage/ temperature/pack voltage/current measurement, passive balance control, CAN bus, RS485, TTL port, Bluetooth (APP supported), SOC calculation, MOS control.

1.2 System Topology

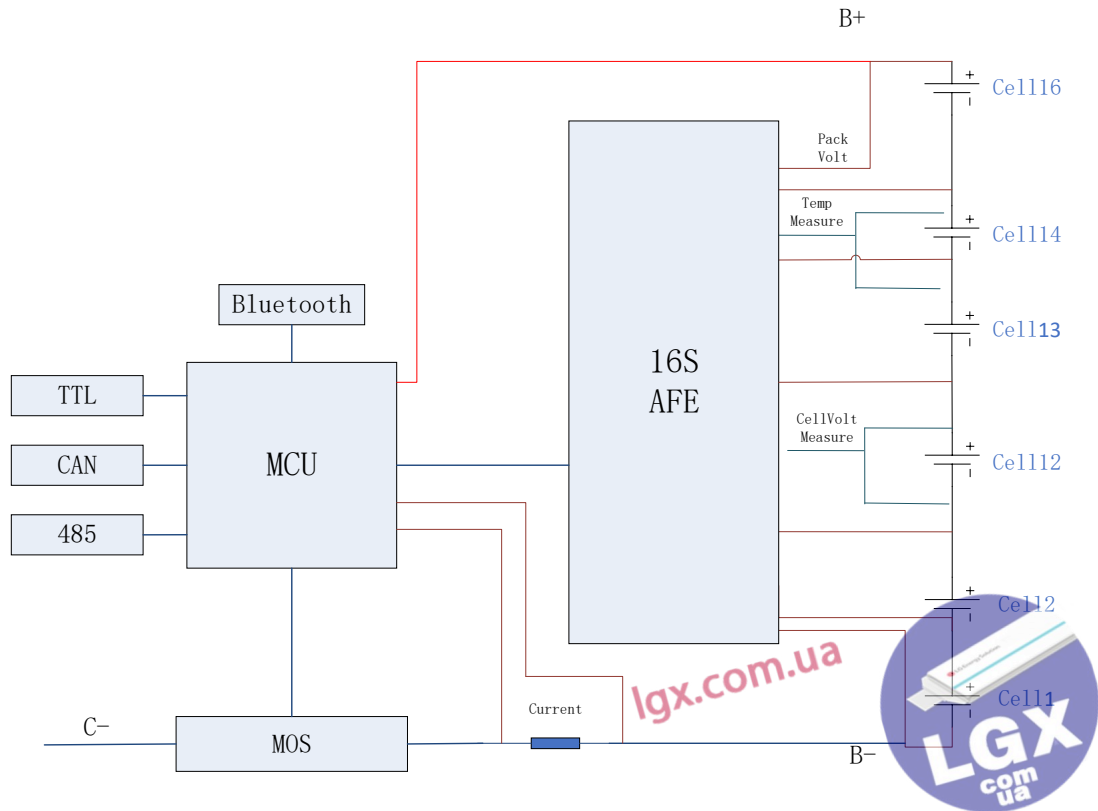

1.3 Function

1.3.1 CAN Bus

JN1939 protocol, CAN2.0A/B supported. 2500V isolated.

CAN /485/TTL can only choose one.

1.3.2 RS485 Bus

2500V isolated。 Typical baud rate is 19200.

CAN /485/TTL can only choose one.

1.3.3 TTL Port

2500V isolated。 Typical baud rate is 19200.

Need external isolated power.**CAN /485/TTL can only choose one.**

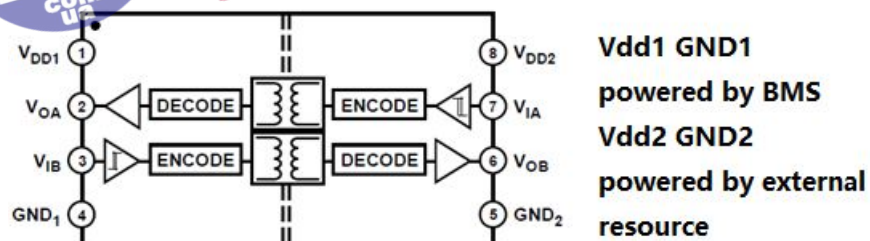

- 1.3.4 Cell voltage measurement
Measures Up to 16 Battery Cells in Series.
- 1.3.5 Temperature measurement
MOS, balance circuit, and external temperature measurement.
- 1.3.6 SOC
AH integral method with OCV calibration.
- 1.3.7 MOS Control
Drive charge & discharge MOS to protect the battery.
- 1.3.8 Pack voltage measurement
Pre-charge and pack voltage are get by this function.
- 1.3.9 Current measurement
Short-circuit, auto wake up, soc calculation.
- 1.3.10 Balancing
Passive cell balancing with programmable current.
100mA/ channel for maximum.



1.4 Electrical characteristics

Index	Parameter	Detail	Remark
1	Total supply voltage	20-80V DC from battery	Auto change to sleep state
2	Cell number	7-16S	
3	Working state power consumption	< 10mA (60V)	
4	Sleep state power consumption	< 5mA (60V)	Auto wake up
5	Deep sleep state power consumption	< 20uA (60V)	Manual wake up
6	Working temperature	-40 ~ 85 °C	
7	Storage temperature	-40 ~ 95 °C	
8	Working humidity	5% ~ 95%	Conformal Coating
9	Cell voltage measurement	0-5V, measurement error< 10mV Typical is 5mV	Resolution 1mV
10	Open wire detection	Supported	
11	Passive balancing	Maximum 100mA/channel	
12	Temperature measurement	-30 ~ 125 °C ,	2 channels
13	Pack voltage measurement	1 channel. 0-100V. error <0.5% FSR.	
14	Current measurement	-150A ~ 300A, error<0.5% FSR	1channel
15	SOC	< 8%	
16	CAN	1 channel, bootloader supported	Choose one in three
17	485	1 channel, bootloader supported	Choose one in three
18	TTL	1 channel, bootloader supported	Choose one in three
19	Current ability	Rated 100A, Pulse 300A (30s) The value depends highly on heat radiation.	
20	Short circuit	default 300A	

21	System log	Support	FLASH
22	Bluetooth	Support	Connect to APP
23	IP level	IP30	
24	Weight	< 400g	
25	Size	122*72*16mm	

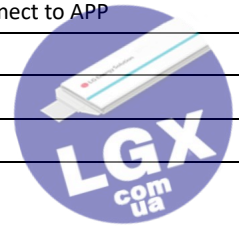

2. Interface definition

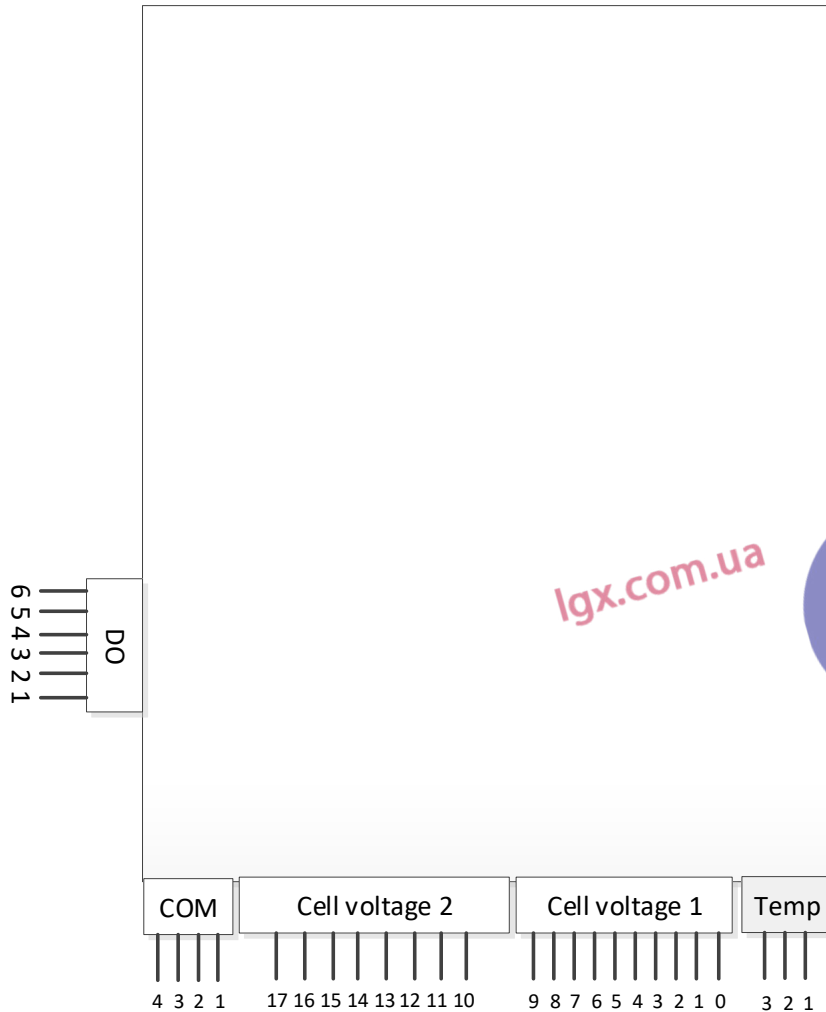

lgx.com.ua



2.1 Output negative:

C-, **Black wire**. Charge and discharge negative share the same port.

2.2 Battery negative:

B-, **blue wire**. Connect to pack negative.

B- must be connected to battery first, then cell voltage interface can be plugged in.

2.3 Cell voltage port

16 series cell voltage and BMS power wire.

Index	Item	Details
0	B-	Connected to pack negative
1	B1+	Connect to positive terminal of cell 1
2	B2+	Connect to positive terminal of cell 2
3	B3+	Connect to positive terminal of cell 3
4	B4+	Connect to positive terminal of cell 4
5	B5+	Connect to positive terminal of cell 5
6	B6+	Connect to positive terminal of cell 6
7	B7+	Connect to positive terminal of cell 7
8	B8+	Connect to positive terminal of cell 8
9	B9+	Connect to positive terminal of cell 9
10	B10+	Connect to positive terminal of cell 10
11	B11+	Connect to positive terminal of cell 11
12	B12+	Connect to positive terminal of cell 12
13	B13+	Connect to positive terminal of cell 13
14	B14+	Connect to positive terminal of cell 14
15	B15+	Connect to positive terminal of cell 15
16	B16+	Connect to positive terminal of cell 16
17	B+	Connect to pack positive

For application less than 16s, please refer to the wiring guidance!!!

2.4 Temperature port

Index	Item	Details	Index	Item	Details
1	GND	NTC common ground	3	T2	NTC2 positive
2	T1	NTC1 positive			

2.5 Communication port

Index	Item	Details	Index	Item	Details
1	CANL	CAN Low/485B	3	ACC-	Activation negative
2	CANH	CANHigh/485A	4	ACC+	Activation positive

Remark: A Voltage source range from 3-12V can activate BMS via ACC + and ACC-.

By the way, a charger can also activate BMS.

2.6 DO

Index	Item	Details	Index	Item	Details
1	DO1+	DO1 output	4	DO2-	DO2 output
2	DO1-		5	DO3+	DO3 output
3	DO2+	DO2 output	6	DO3-	

3. Wiring

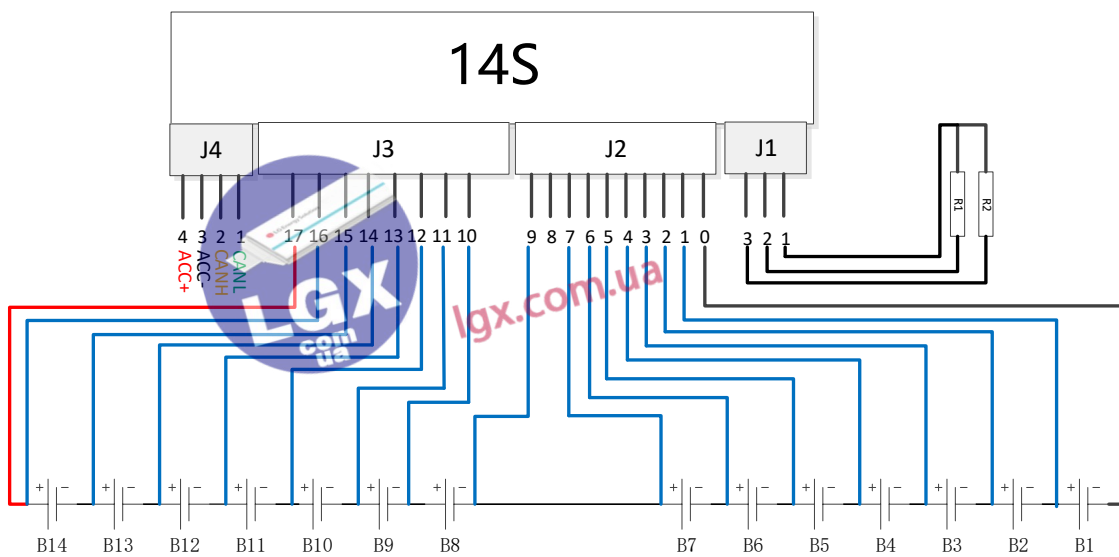
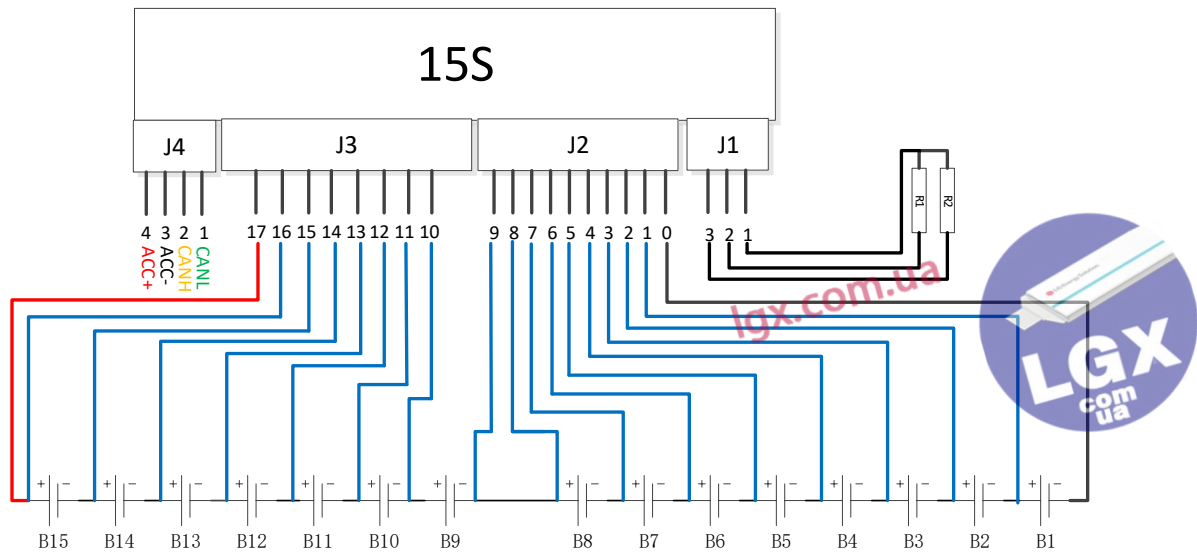
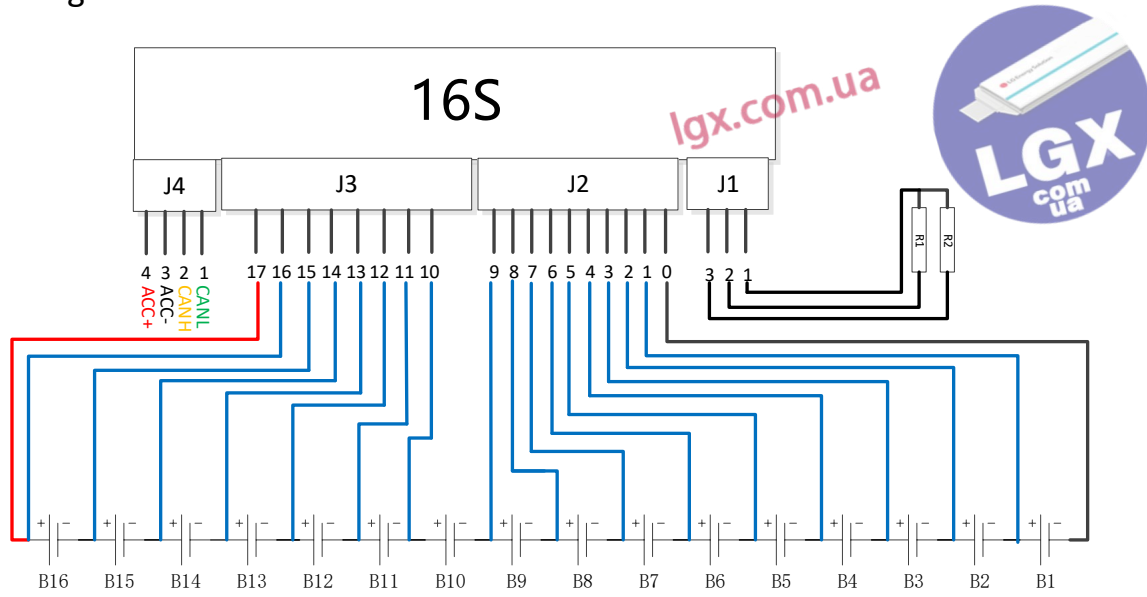

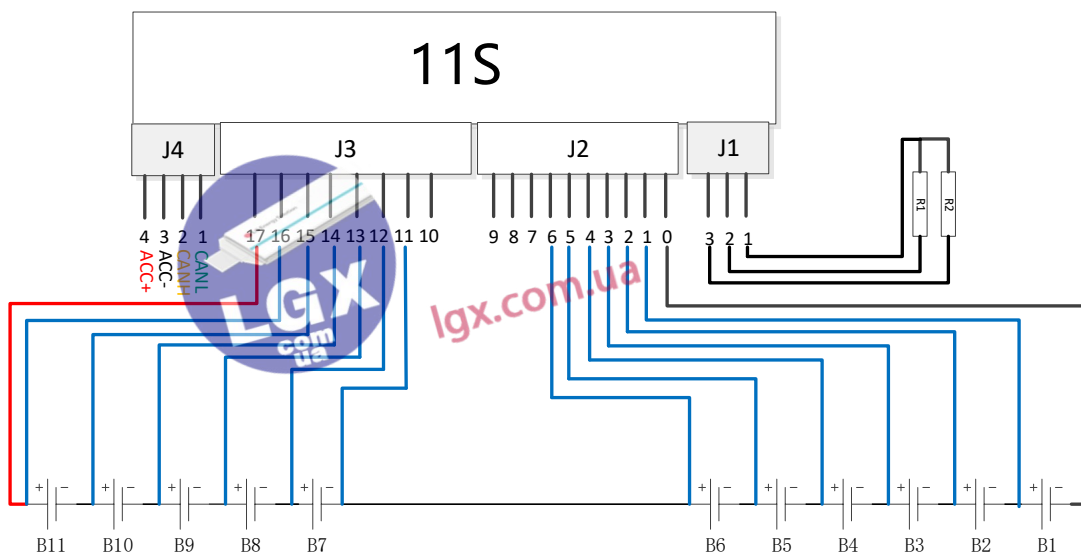
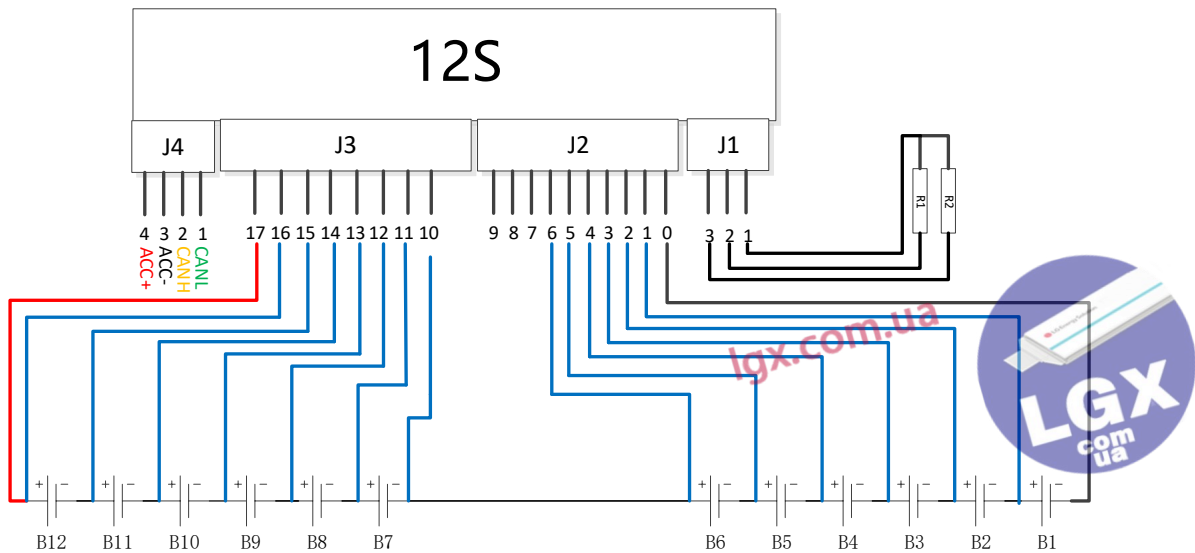
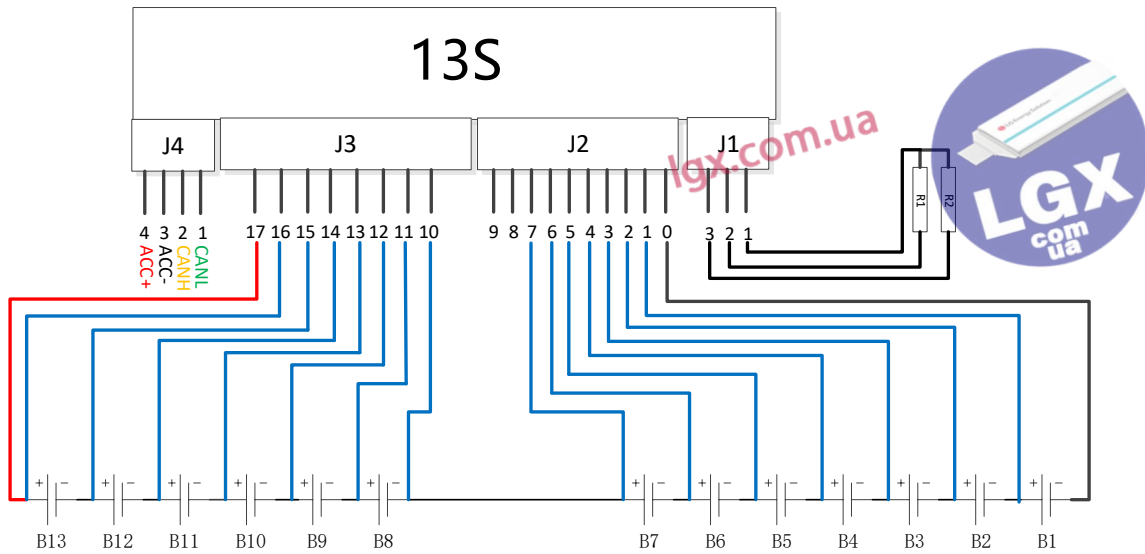

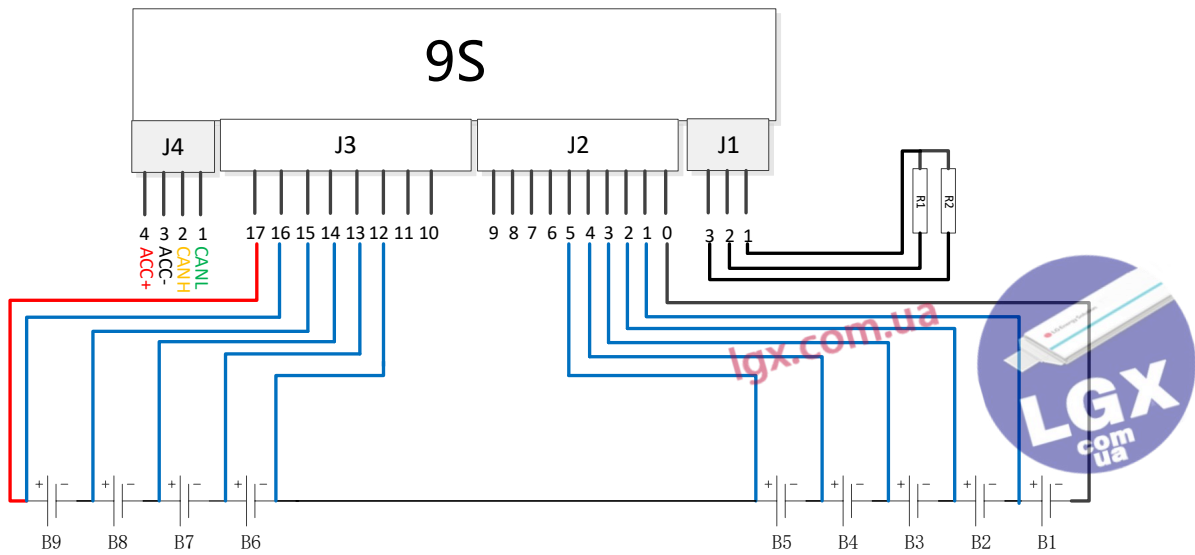
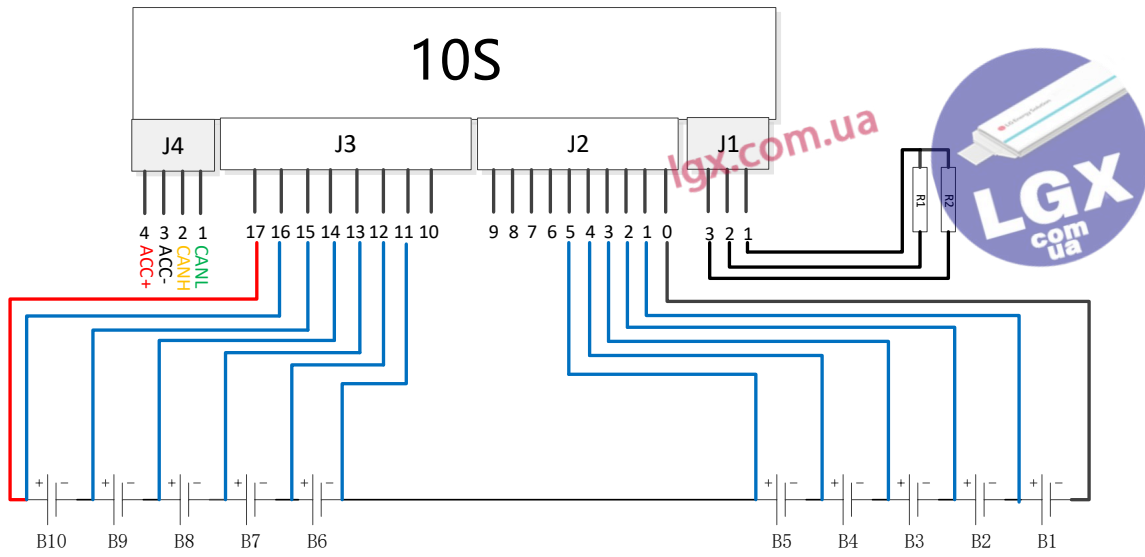

S

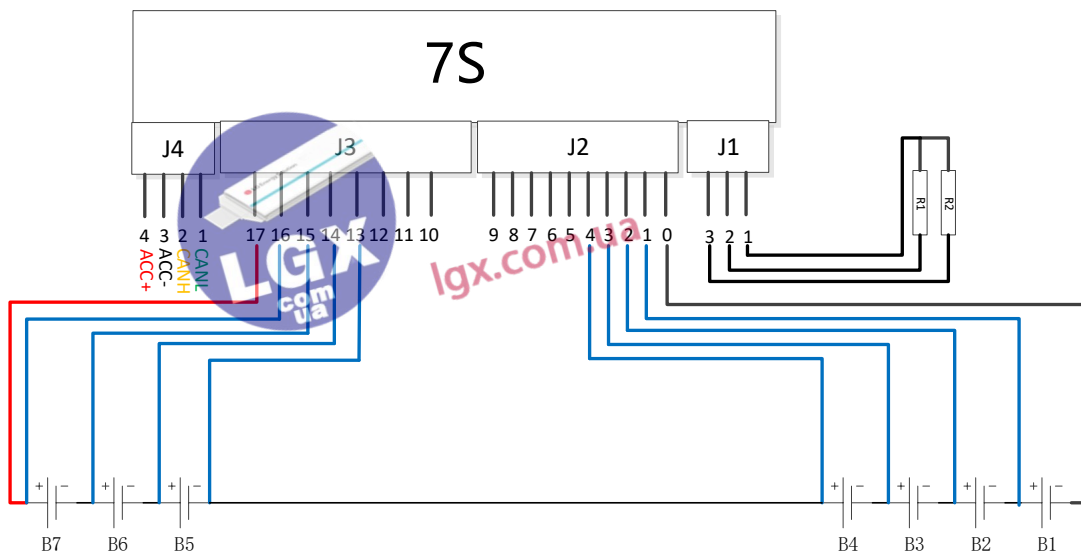

4. PC software



The screenshot shows the BMS_V1.5 software interface with the following sections:

- 连接设置 (Connection Settings):**
 - 端口 (Port): COM3
 - 波特率 (Baud Rate): 19200
 - 按钮: 搜索串口 (Search Serial Port), 关闭串口 (Close Serial Port)
- MOS状态 (MOS Status):**
 - 充电MOS (Charge MOS): 开启 (On)
 - 放电MOS (Discharge MOS): 开启 (On)
 - 均衡状态 (Balancing Status): 关闭 (Off)
- 单体电压 (Cell Voltage):**

单体01: 4.035V	单体02: 4.035V	单体03: 4.035V	单体04: 4.035V
单体05: 4.035V	单体06: 4.035V	单体07: 4.035V	单体08: 4.035V
单体09: 4.035V	单体10: 4.035V	单体11: 4.035V	单体12: 4.035V
单体13: 4.035V	单体14: 4.035V	单体15: 4.035V	单体16: 4.035V
- 电池概况 (Battery Overview):**
 - 总压: 64.6V
 - 最高(1): 4.035V
 - MOS: 11°C
 - 电流: 000.0A
 - 最低(1): 4.035V
 - 均衡: 11°C
 - SOC: 89%
 - 平均: 4.035V
 - T1: -40°C
 - 剩余容量: 88.299AH
 - 压差: 0.000V
 - T2: -40°C
- 系统日志 (System Log):**

调试参数1: 12.8V	调试参数2: 13.0V	调试参数3: 0.0V
0 <放电> (0) 开启	10 <充电> (1) 充电管异常	20 <充电> (0) 开启
1 <充电> (0) 开启	11 <放电> (0) 开启	21 <放电> (0) 开启
2 <放电> (0) 开启	12 <充电> (0) 开启	22 <充电> (0) 开启
3 <充电> (0) 开启	13 <放电> (0) 开启	23 <放电> (0) 开启
4 <放电> (0) 开启	14 <充电> (0) 开启	24 <充电> (0) 开启
5 <充电> (0) 开启	15 <放电> (0) 开启	25 <放电> (0) 开启
6 <放电> (0) 开启	16 <充电> (0) 开启	26 <充电> (0) 开启
7 <充电> (0) 开启	17 <放电> (0) 开启	27 <放电> (0) 开启
8 <放电> (0) 开启	18 <充电> (0) 开启	28 <充电> (0) 开启
9 <充电> (0) 开启	19 <放电> (0) 开启	29 <放电> (0) 开启
- 控制 (Control):**
 - 按钮: 打开充电 (Open Charge), 自动均衡 (Auto Balancing), 关闭充电 (Close Charge), 电流归零 (Current Zero)
 - 按钮: 关闭放电 (Close Discharge), 重启系统 (Restart System)
 - 按钮: 打开放电 (Open Discharge), 关闭系统 (Close System)



lgx.com.ua

lgx.com.ua



5. APP



The screenshots show the following interface elements:

- BMS Control:** Includes a '连接...' (Connect...) header, '设置可见' (Settings Visible), '连接设备' (Connect Device), and '系统日志 >>' (System Log >>). Below are password verification fields and buttons for '钛锂参数' (Titanium/Lithium Parameters), '打开充电' (Open Charge), '打开放电' (Open Discharge), '修改蓝牙地址' (Modify Bluetooth Address), '关闭充电' (Close Charge), '关闭放电' (Close Discharge), '重启系统' (Restart System), '出厂设置' (Factory Settings), '屏幕切换' (Screen Switch), '自动均衡' (Automatic Balancing), '铁锂参数' (Iron/Lithium Parameters), and '电流归零' (Current Zero). At the bottom are 'BMS控制', '参数设置', and '实时状态' tabs.
- BMS Parameter setting:** A table for setting machine parameters.

项目	机器参数	设定参数	设置
单体过压告警	0 V	0	设置
单体欠压告警	0 V	0	设置
单体过压保护	0 V	0	设置
单体欠压保护	0 V	0	设置
单体过压恢复	0 V	0	设置
单体欠压恢复	0 V	0	设置
总压过压保护	0 V	0	设置
总压欠压保护	0 V	0	设置
充电过流保护	0 A	0	设置
充电过流延时	0 S	0	设置

 Includes '刷新BMS参数' (Refresh BMS Parameters) and 'BUTTON' at the bottom.
- BMS State:** Displays real-time data including RV:16043, 运行时间:53天1时31分17秒, 总压 64.6 V, 电流 0.0 A, 容量 88.299 AH, 总循 0, 最高 4.035 V, 平均 4.035 V, MOS 11 °C, T1 -40 °C, T3 -40 °C, 放电MOS: 开启, 均衡: 关闭, 功率 0 W, 最低 4.035 V, 压差 0.000 V, 均衡 11 °C, T2 -40 °C, T4 -40 °C, and a list of cell voltages from [01] to [16], all at 4.035 V.

BMS Control

BMS Parameter setting

BMS State

6. Part Number definition

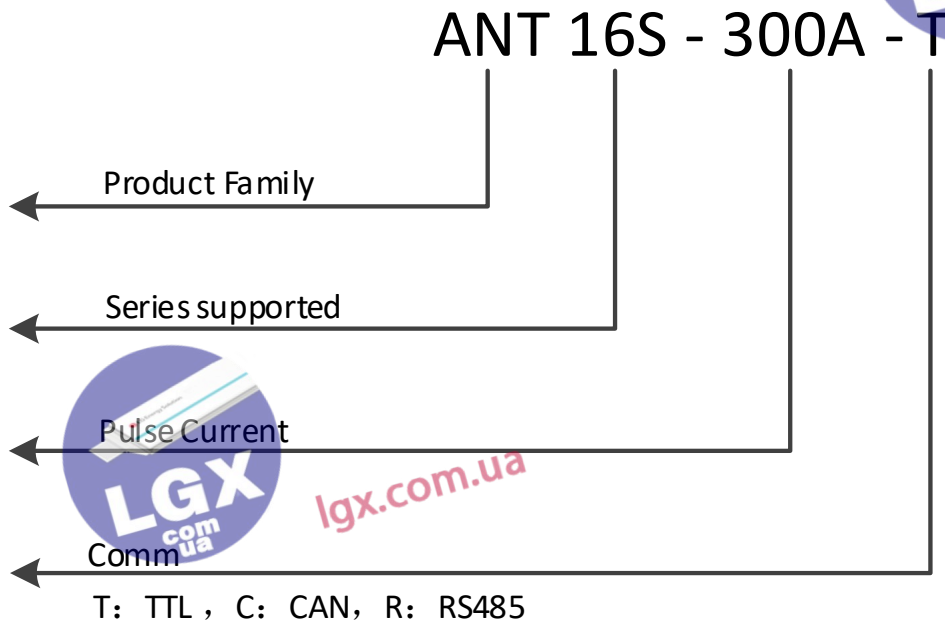

Example: ANT16S-300A-C means 16S pulse current 300A, CAN port
 ANT16S-300A-T means 16S pulse current 300A, TTL port

7. Structure

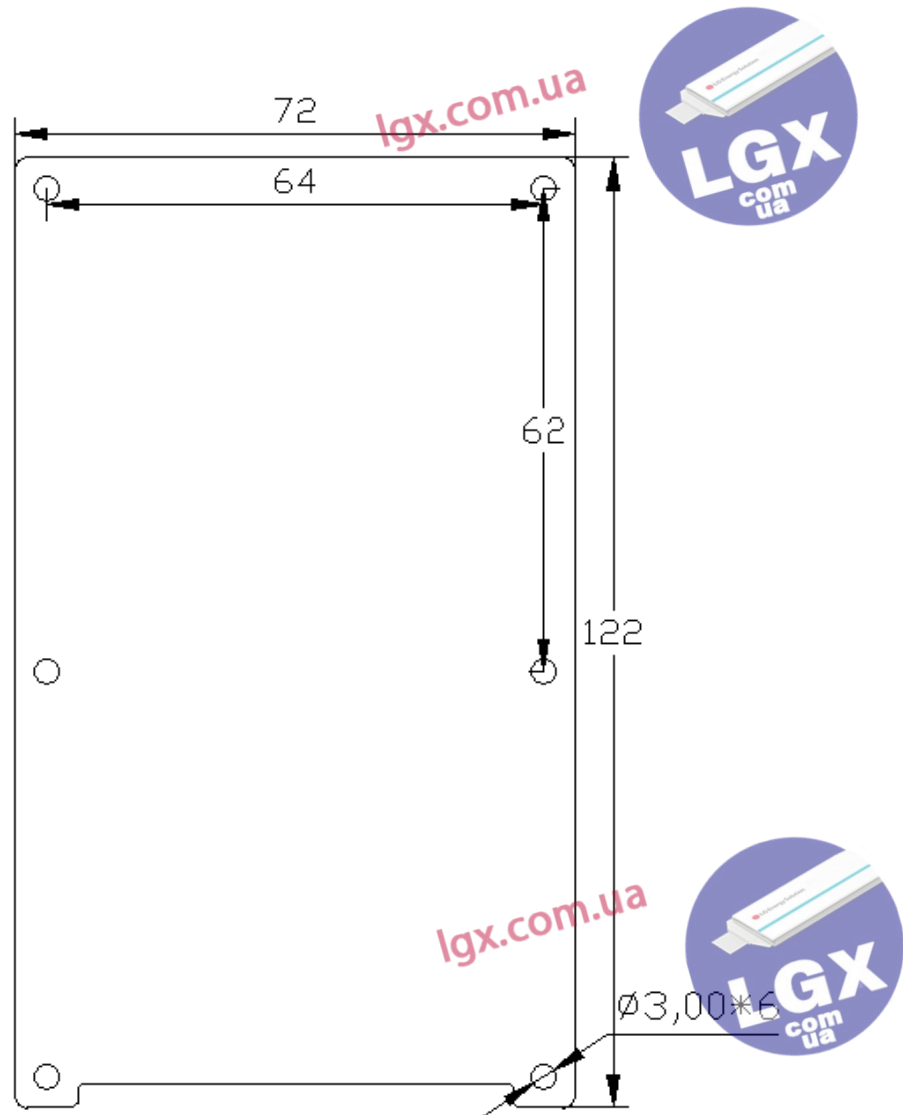

Default without fixing hole



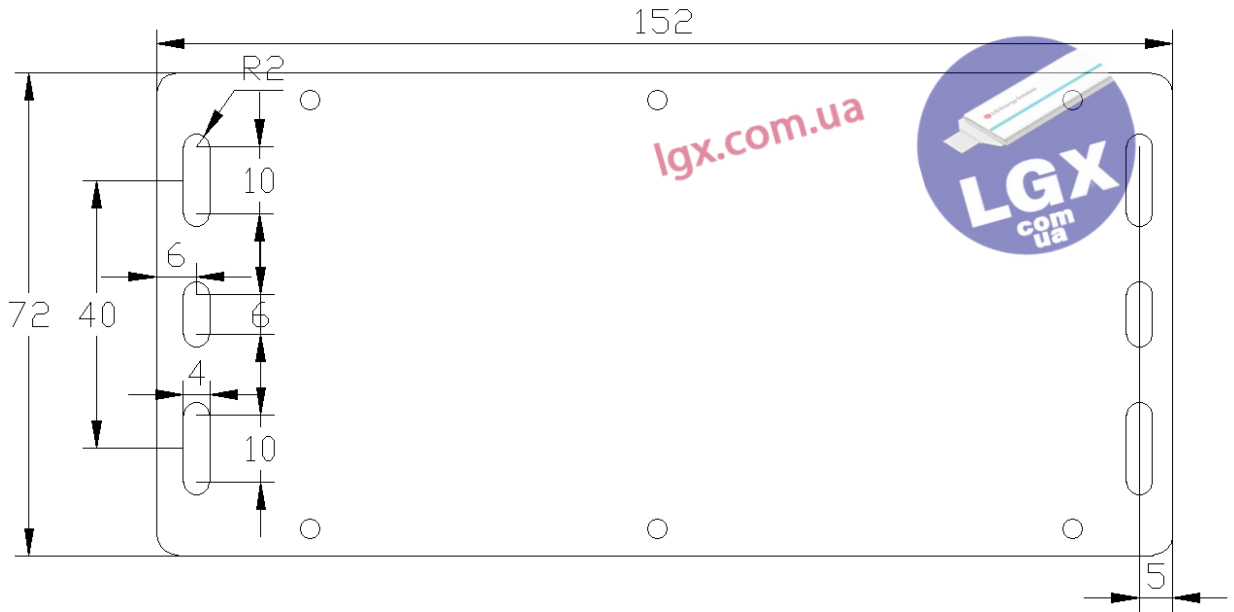

With fixing hole for option

lgx.com.ua



lgx.com.ua